

OKI

**CUT-SHEET FEEDER
3390-S/3390-D/3391-S/3391-D
for ML 3320/3321, ML 3390/3391**

Maintenance Manual

OEL

PREFACE

This manual for field maintenance personnel describes the operation and maintenance procedure of the cut-sheet feeder (CSF) used as an option with the ML3320/3321, ML3390/3391 printers. For details regarding the printer, refer to the printer maintenance manual.

CONTENTS

1. OVERVIEW	1 - 1
1.1 Functions	1 - 1
1.2 External View and Name of Parts	1 - 2
1.3 Cut-Sheet Feeder (CSF) Models and Compatible Printer Units	1 - 4
2. OPERATION	2 - 1
2.1 Drive Mechanism	2 - 1
2.2 Hopper Mechanism	2 - 1
2.3 Stacker Mechanism	2 - 1
2.4 Signal Control	2 - 3
3. PARTS REPLACEMENT	3 - 1
3.1 Precautions on Parts Replacement	3 - 1
3.2 How to Change Parts	3 - 2
3.2.1 Side Cover (L), (R)	3 - 3
3.2.2 Circuit Board NCSF	3 - 4
CSF 3390-S 3.2.3 Pulse Motor (Hopping)	3 - 5
CSF 3391-S 3.2.4 Hopping Roller Assy	3 - 6
3.2.5 Brake Shoe	3 - 7
3.2.6 Friction Sheet	3 - 8
3.2.7 Side Cover (L), (R)	3 - 9
3.2.8 Circuit Board NCSF-2	3 - 10
CSF 3390-D 3.2.9 Pulse Motor (Hopping)	3 - 11
CSF 3391-D 3.2.10 Sheet Guide	3 - 12
3.2.11 Hopping Roller Assy	3 - 13
3.2.12 Brake Shoe	3 - 14
3.2.13 Friction Sheet	3 - 15
3.2.14 Attachment Assy	3 - 16
4. PERIODIC MAINTENANCE	4 - 1
4.1 Periodic Replacing Parts	4 - 1
4.2 Lubrication	4 - 1
5. TROUBLESHOOTING FLOWCHARTS	5 - 1
6. CIRCUIT DIAGRAM	6 - 1
7. PARTS LIST	7 - 1

1. OVERVIEW

1. OVERVIEW

1.1 Functions

The Cut-Sheet Feeder (CSF) is mounted on top of the printer. This feeder supplies cut-sheet paper automatically to the printer by means of rotating a stepping motor in accordance with signals from the printer.

The main features of the CSF are summarized below.

(1) Paper size

	CSF 390T-S	CSF 391T-S	CSF 390T-D	CSF 391T-D
Width	7.2 to 8.5 inches (182 to 216 mm)	7.2 to 14.3 inches (182 to 364 mm)	7.2 to 8.5 inches (182 to 216 mm)	7.2 to 14.3 inches (182 to 364 mm)
Length	7.2 to 14 inches (182 to 356 mm)	7.2 to 14.3 inches (182 to 364 mm)	1Bin 7.2 to 14 inches (182 to 356 mm) 2Bin 7.7 to 14 inches (195 to 356mm)	1Bin 7.2 to 14.3 inches (182 to 364 mm) 2Bin 7.7 to 14.3 inches (195 to 364mm)

Cut Form Envelope (On the CSF3390-D/3391-D, to be applicable to Bin 1 side only.)

Size: 9-1/2 inches (241 mm) (W) x 4-1/8 inches (104.8 mm) (L)
Weight: 24 lbs (90 g/m²) or less
Thickness: 0.016 inches (0.41 mm) or less

- (2) You can set a single cut sheet in the feeder unit if you use the manual feed (manual set) mode. (Interruption of automatic paper feed operation is available.)
- (3) This feeder unit enables you to set the desired print start position within the effective print area.

1.2 External View and Name of Parts

C.S.F 3390-S

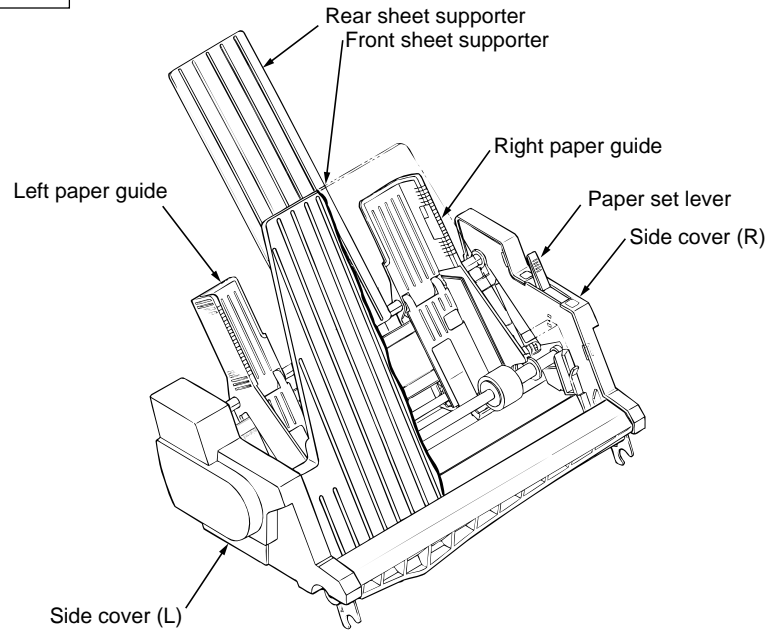

C.S.F 3390-D

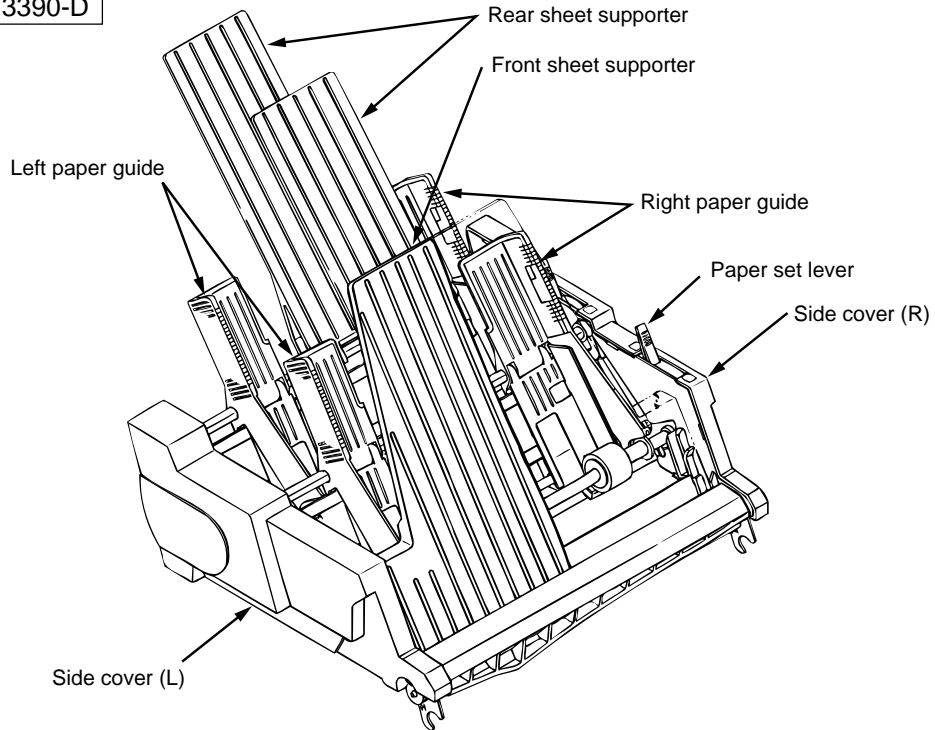
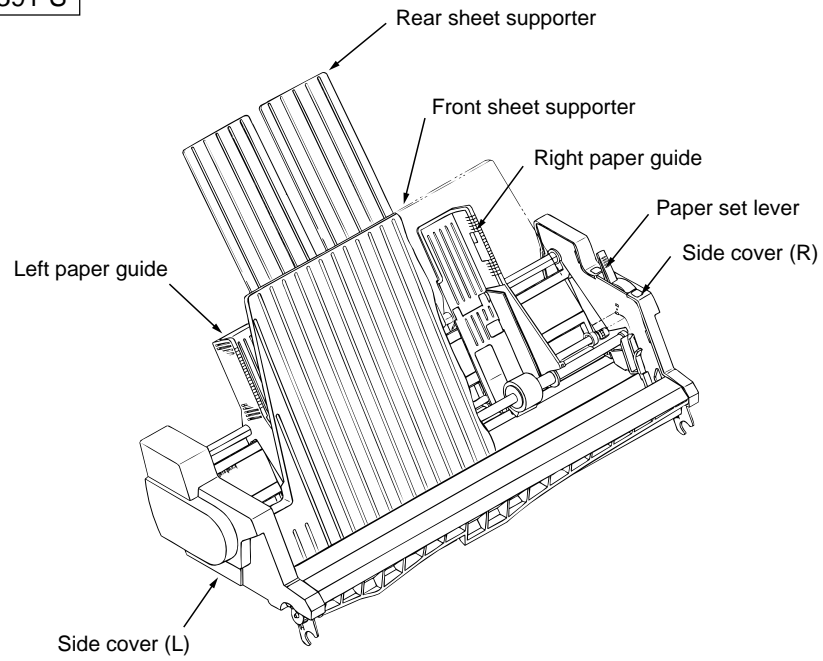

Fig. 1-1 External View and Name of Parts(1/2)

C.S.F 3391-S



C.S.F 3391-D

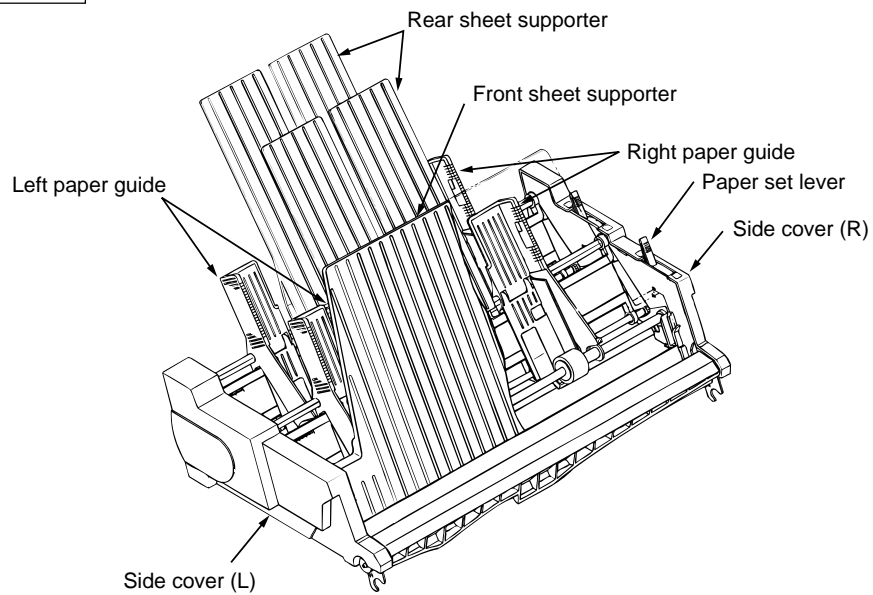

Fig. 1-1 External View and Name of Parts(2/2)

1.3 Cut-Sheet Feeder (CSF) Models and Compatible Printer Units

Cut-Sheet Feeders are of four types. These CSFs and the printer units they can be mounted on are listed below.

C.S.F Name	Printer Unit
Cut-Sheet Feeder 390T-S	ML320T,ML390T, ML321T, ML391T
Cut-Sheet Feeder 391T-S	ML321T,ML391T,
Cut-Sheet Feeder 390T-D	ML320T,ML390T, ML321T, ML391T
Cut-Sheet Feeder 391T-D	ML321T, ML391T

2. OPERATION

2. OPERATION

2.1 Driving Mechanism

Signals sent from the printer cause the CSF to rotate its built-in stepping motor. The generated power is transmitted to the hopper roller gear which rotates the hopping roller. The hopping roller rotation draws out a paper sheet and loads it into the printer. The paper loaded into the printer is controlled and fed by the printer LF motor.

2.2 Hopper Mechanism

The hopper unit automatically feeds the paper set in the feeder unit one by one to the printer. When you push the paper set lever to the reset position, the opening through which paper is supplied becomes wider and paper can be added. After setting the paper, complete paper feeding preparations by carefully moving the paper set lever forward to the set position.

The paper feeding operation can be carried out then by the stepping motor which will feed only one sheet of paper that is caught in the brake shoe.

2.3 Stacker Mechanism

The paper drawn out from the hopper is controlled by the LF motor assembly in the printer and is sent to the stacker roller alongside the front sheet guide through the gap between the paper pressure roller and platen. The stacker roller sends the paper sequentially to the stacker.

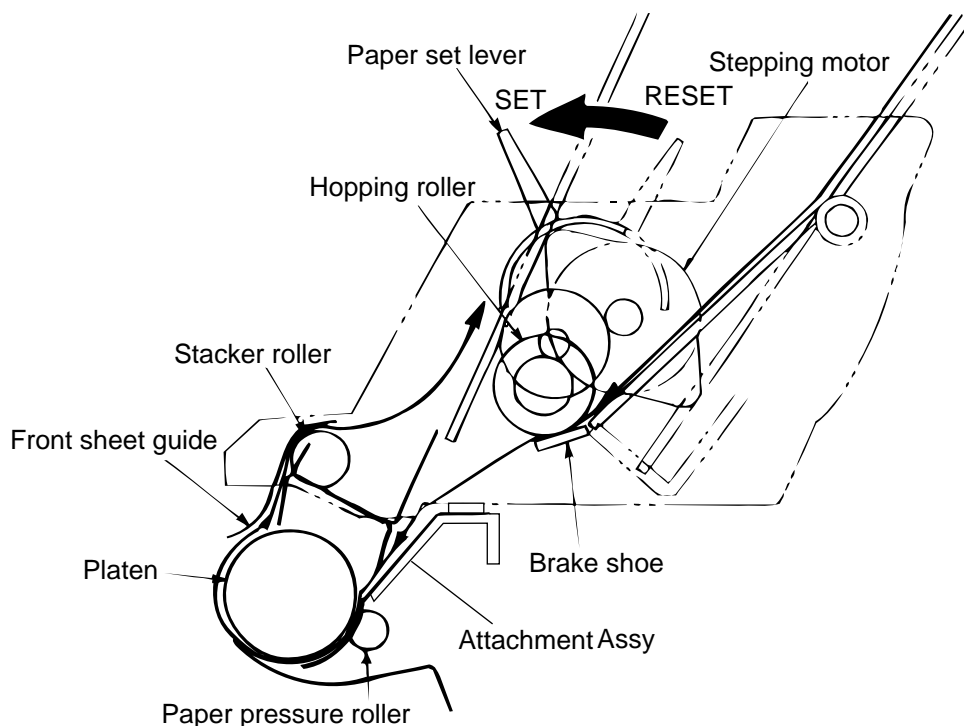

Fig. 2-1 CSF 3390-S/3391-S Mechanism

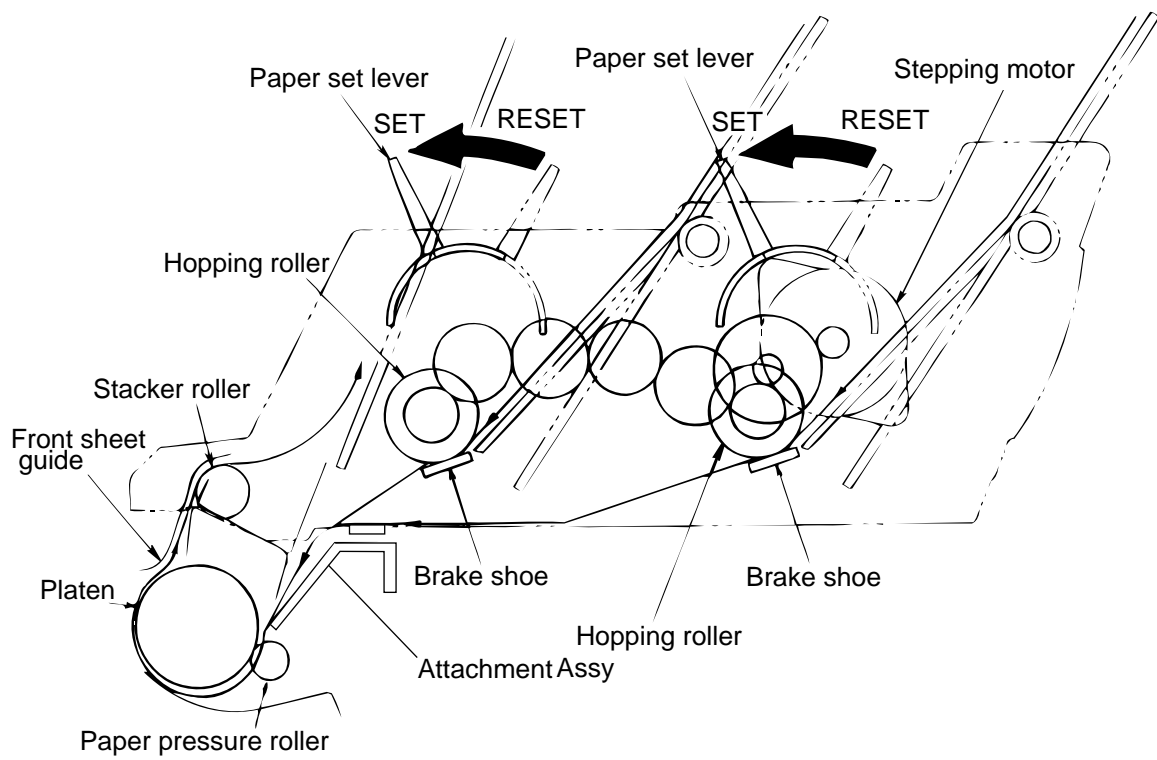
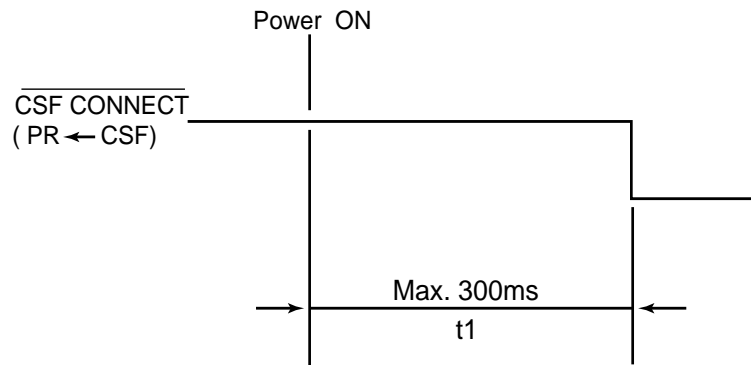

Fig. 2-2 CSF 3390-D/3391-D Mechanism

2.4 Signal Control

(1) CSF Selection

The $\overline{\text{CSF CONNECT}}$ signal level change from "high" to "low" a maximum of 300 ms after the power is turned on.



The CSF outputs this signal regardless of whether the paper has run out.

(2) CSF Reset

When power to the printer is turned on or when an I-Prime signal is received, the printer outputs a Reset command to reset the CSF and make an attribute check.

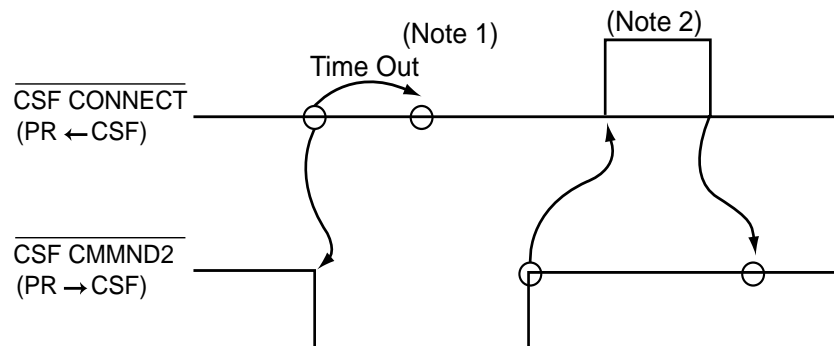

Note 1: The CSF monitors the time during which the $\overline{\text{CSF CMMND2}}$ signal is at the "low" level. If the signal level continues to be low for 40 ms or more, the CSF recognizes it to be a Reset command and performs the reset operation at the leading edge of the signal.

Note 2: CSF 3390-D/3391-D only

The CSF must change the $\overline{\text{CSF CONNECT}}$ signal level from "low" to "high" within 0.5 ms after detecting the leading edge of the $\overline{\text{CSF CMMND2}}$ signal and then must return it to "low" within 4 ± 1 ms.

- (3) **Attribute Check**
 The Attribute Check command becomes effective after the printer has sent the Reset command to the CSF. After the power is turned on, the CSF can select a bin and feed paper even if no attribute check has been done.

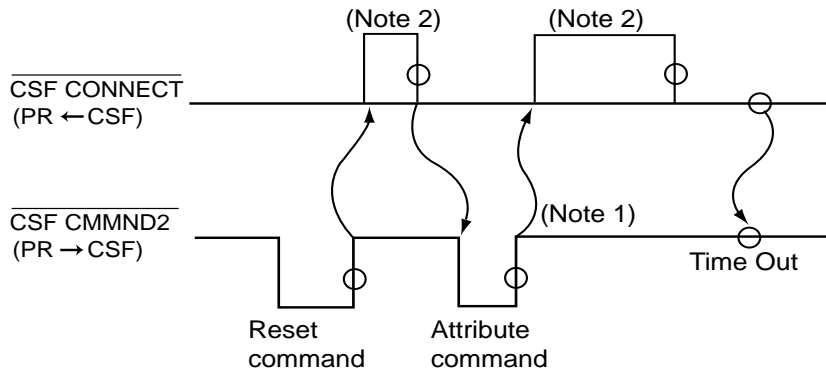

Note 1: The CSF must inform the printer of the number of bins within 1.0 ms after detecting the leading edge of the Attribute command.

Note 2: CSF 3390-D/3391-D only

- (4) **Bin Selection (CSF 3390-D/3391-D only)**

When paper is to be inserted into the printer, the CSF selects a bin.

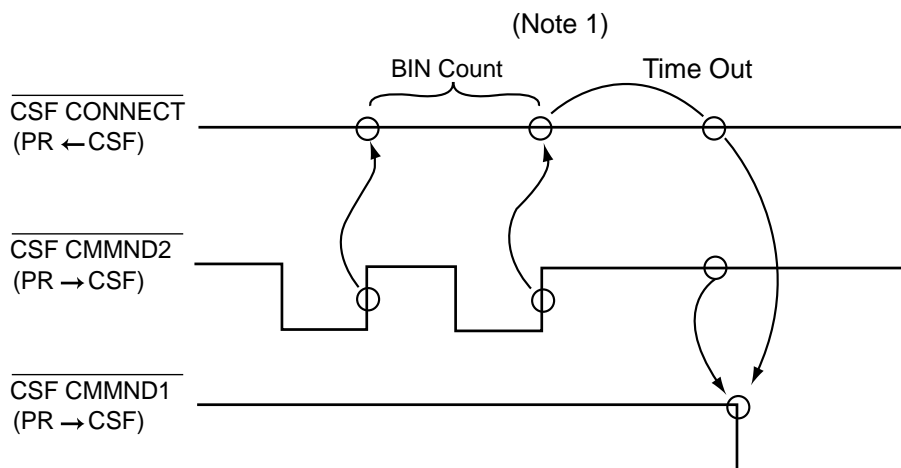

When the power is turned on, the CSF selects the front bin after receiving the Reset command (default).

Note 1: The CSF counts the number of leading edges of the Bin Selection command. If the interval between leading edges exceeds the time-out value, the CSF starts monitoring the CSF CMMND1.

- (5) Starting and Stopping Signal
The CSF motor starts when detecting the $\overline{\text{CSF CMMND1}}$ signal level continues to be low for definite time.

The CSF motor stops when detecting the $\overline{\text{CSF CMMND1}}$ signal level is at high.

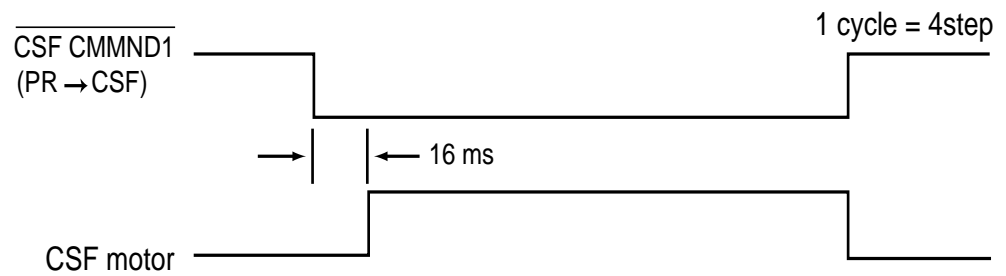

3. PARTS REPLACEMENT

3. PARTS REPLACEMENT

This section explains the field service assembly unit removing procedures. Be sure to reinstall the unit in the reverse order of the removing procedure.





3.1 Precautions on Parts Replacement

- Before you disassemble and reassemble the CSF, turn off the printer power and disconnect the CSF from the printer.
- When the CSF operations are normal, never disassemble the unit.
- Never disassemble more parts of the unit than are necessary. Determine the range of the assembly work in accordance with the purpose of the job.
- Use the designated maintenance service tools.
- Be sure to disassemble the unit in the designated order. Disassembling the unit in the wrong order may damage its parts.
- Since small parts such as screws and collars get lost easily, keep them loosely fixed in their original locations.
- Do not use a pair of gloves that tends to generate static electricity when you handle the printed circuit boards. Do not place the printed circuit boards directly on the equipment or floor.
- Before you start the disassembly work, remove the front and rear sheet supporters.

[Service tools]

Table 3-1 shows the tools required for field replacement of printed circuit board and units.

Table 3-1 Service Tools

No	Service Tools	Q'ty	Place of use	Remarks
1	 No. 2-100 Philips screw driver	1	3mm screws	
2	 No. 3-100 Flat blade screw driver	1		
3	 Multimeter	1		
4	 Pliers	1		

3.2 How to Change Parts

This section explains how to change parts and assemblies appearing in the disassembly diagram below.

CSF 390T-S/ 391T-S

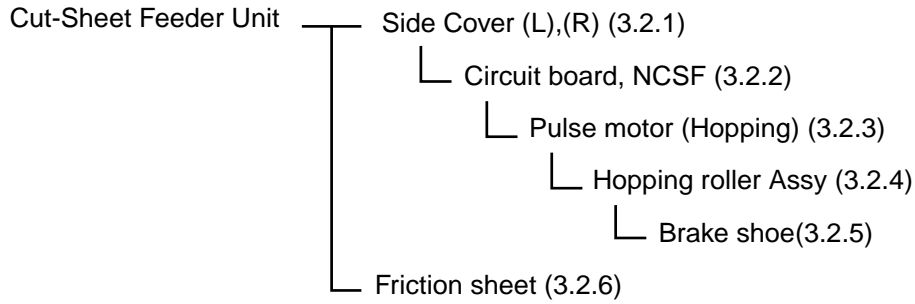

CSF 390T-D/ 391T-D

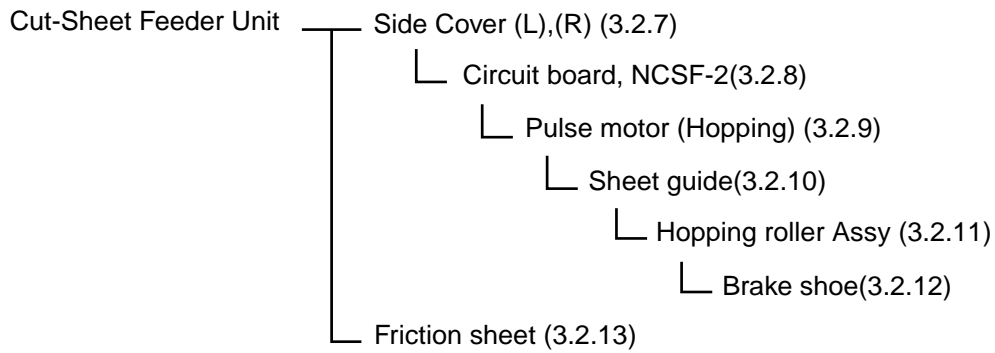

Attachment Assy(3.2.14)

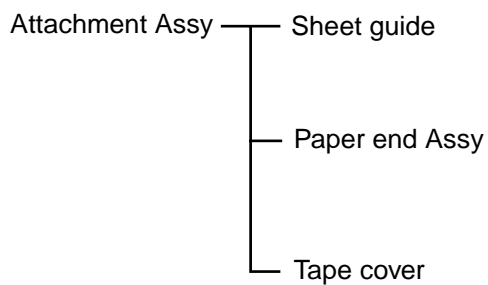

3.2.1 Side Cover (L), (R)

Use the following procedure to remove the side cover (L) and (R).

1. Insert a flat blade screwdriver into the four locking devices on each of the side covers (L) ① and (R) ② and unlock them.
2. Detach side covers (L) ① and (R) ② from the side brackets (L) ③ and (R) ④ respectively.
 - Make sure all locking devices are completely unlocked before removing side covers.
 - Be sure to unlock the four locking devices of both side covers at the same time.

Note on reassembly:

- Be sure to insert the side covers straight along the side brackets until they lock.
- Side cover (R) installation
When installing the side cover (R), make sure that the Paper Set Lever is on the set side.
- Side cover (L) installation
When installing the side cover (L), be careful not to pinch the connector cable.

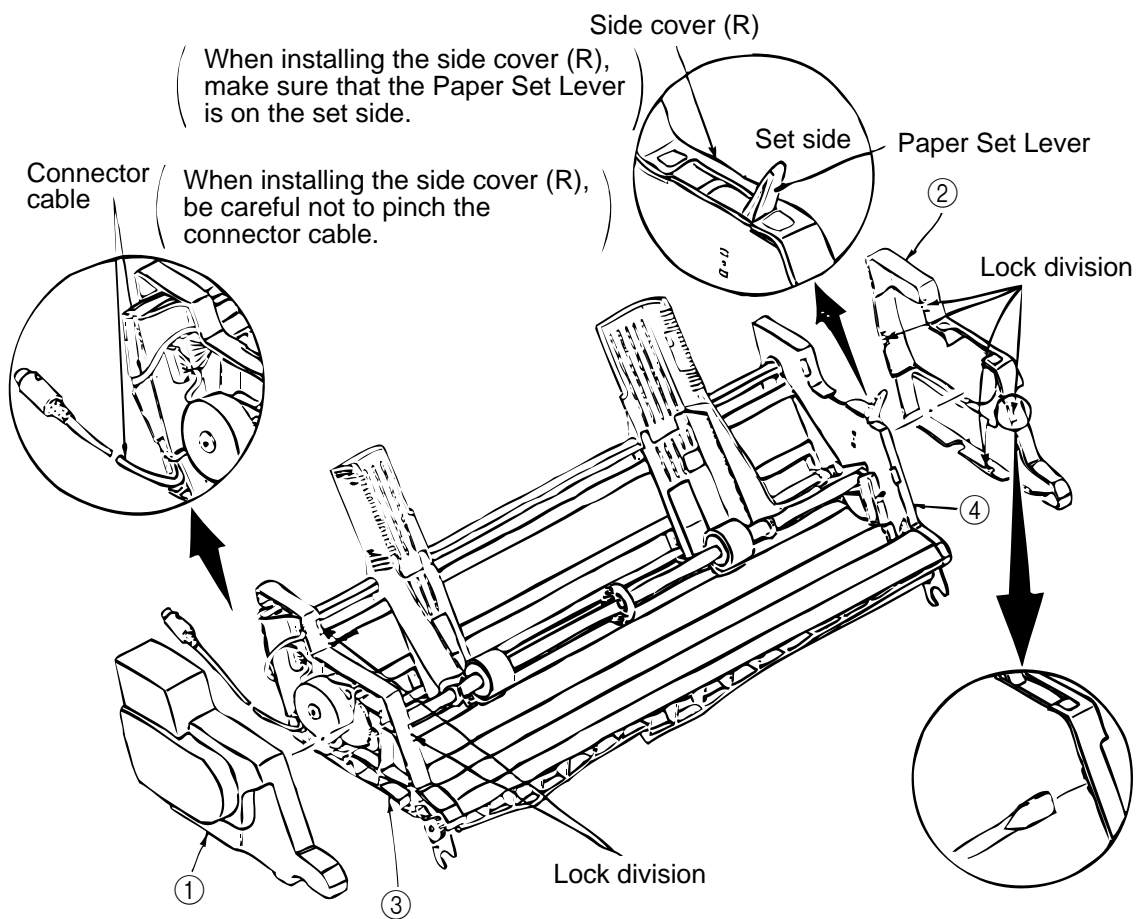

3.2.2 Circuit Board NCSF

1. Remove the side cover (L). (See 3.2.1.)
2. Pull out the circuit board NCSF ①.
3. Disconnect the cables ② connected with the circuit board NCSF ①.

Note on reassembly:

- Insert the circuit board NCSF along the grooves of both upper and lower guides. Make sure it is flush inside bracket.

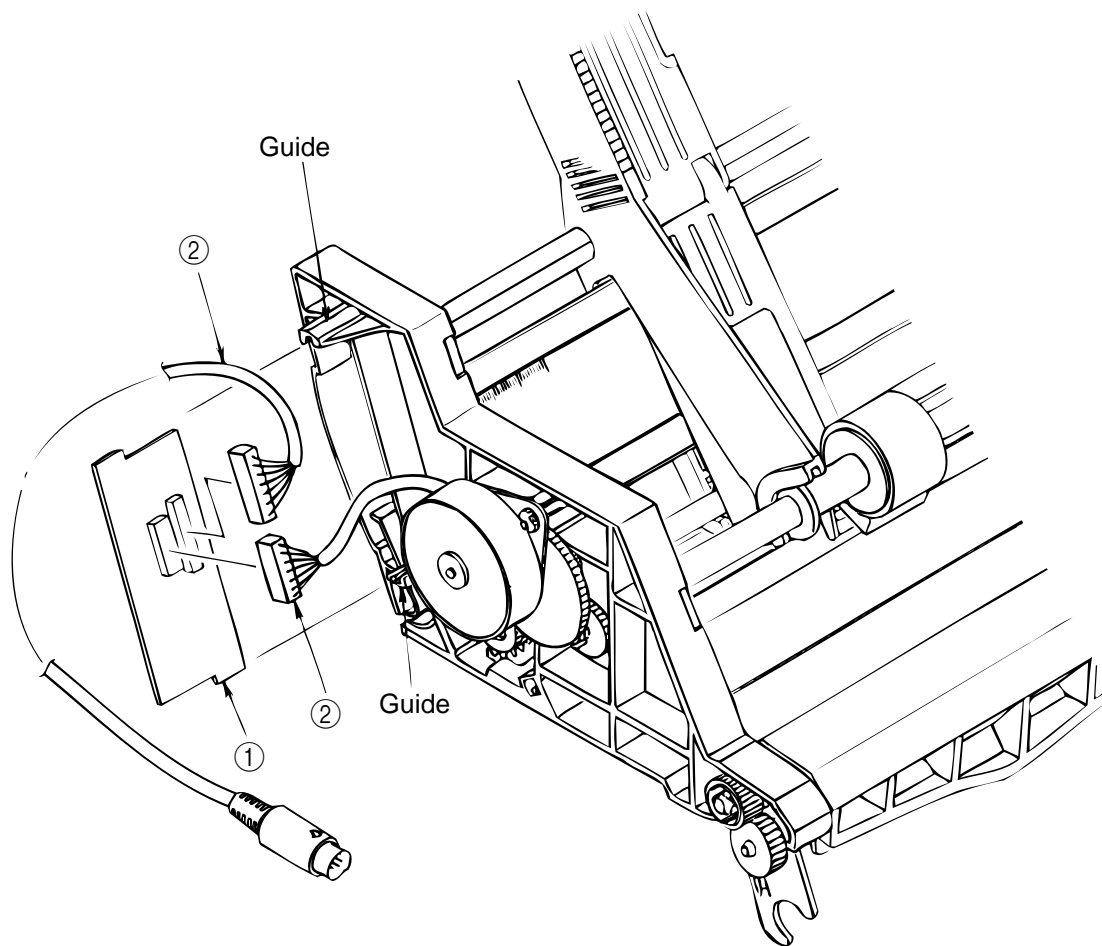

3.2.3 Pulse Motor (Hopping)

1. Remove the side cover (L). (See 3.2.1.)
2. Remove the circuit board NCSF. (See 3.2.2.)
3. Squeeze top of two clamps, in the direction of arrows shown below, to remove the pulse motor ①.
4. Remove the idle gear ② from pulse motor ①.

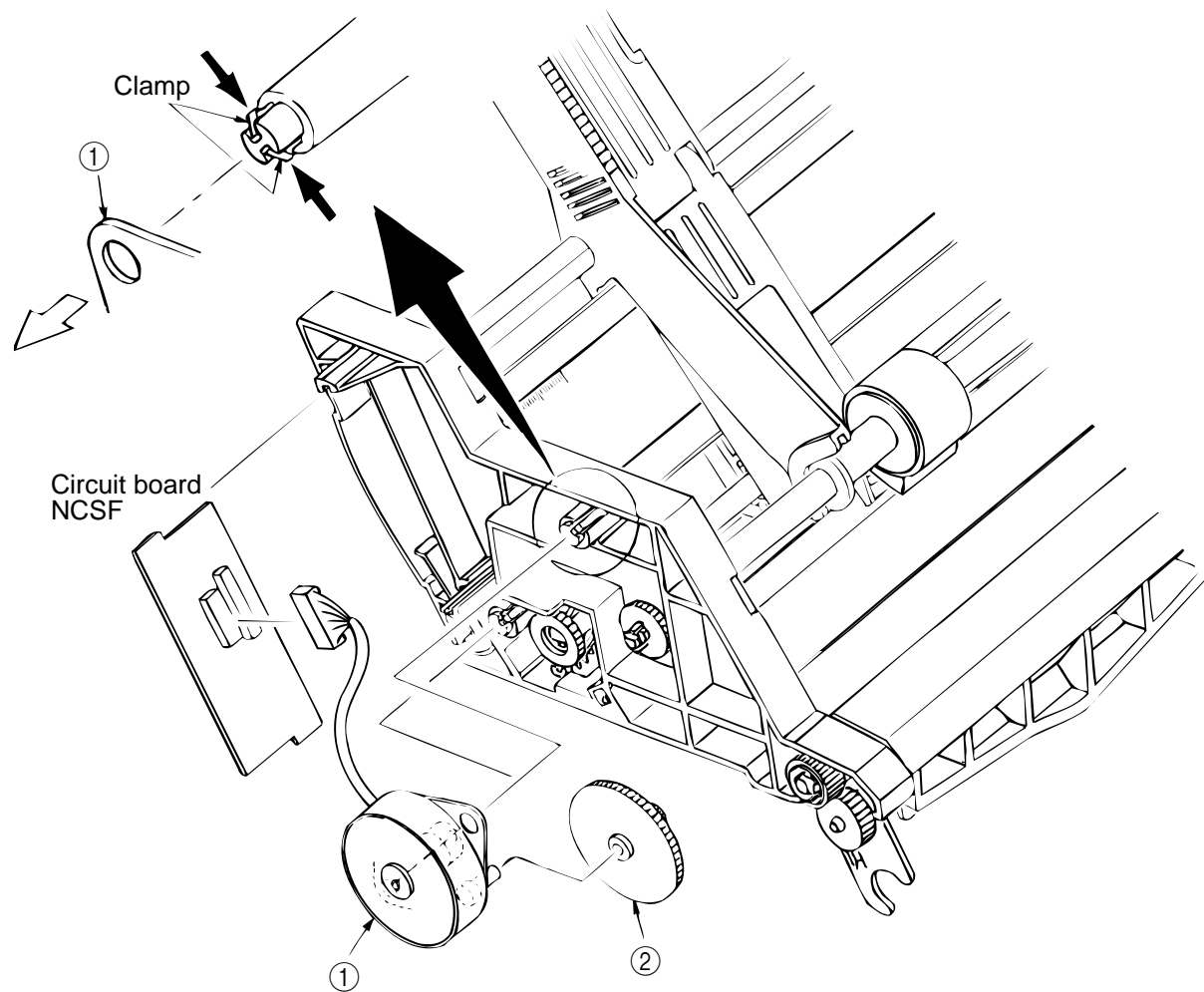

3.2.4 Hopping Roller Assy

- There are two hopping roller assemblies (left and right) and their bearing colors are different.

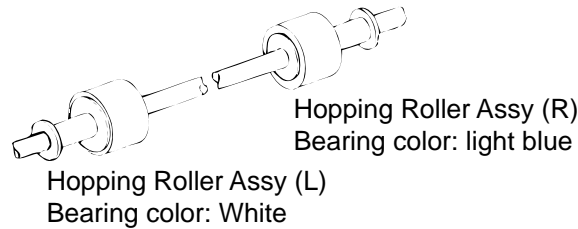

- Be sure to replace both hopping roller assemblies at the same time. If you replace either one separately, this may cause paper skewing later.
1. Remove the side cover (L). (See 3.2.1.)
 2. Remove the pulse motor (hopping). (See 3.2.3.)
 3. Pull out the hopper shaft ① together with the hopper gear.
At this point, the hopper roller assemblies (R) ② and (L) ③ and the guide roller ④ are removed from the shaft.

Note: Be sure not to lose the brake shoe spring.

Notes on reassembly:

- Be sure not to exchange the hopping rollers (R) and (L) when you reinstall them.
- Be sure to insert the flanges of the hopper rollers (R) and (L) into the grooves of the paper guides (R) ⑥ and (L) ⑤ and then reinstall hopper shaft ①.

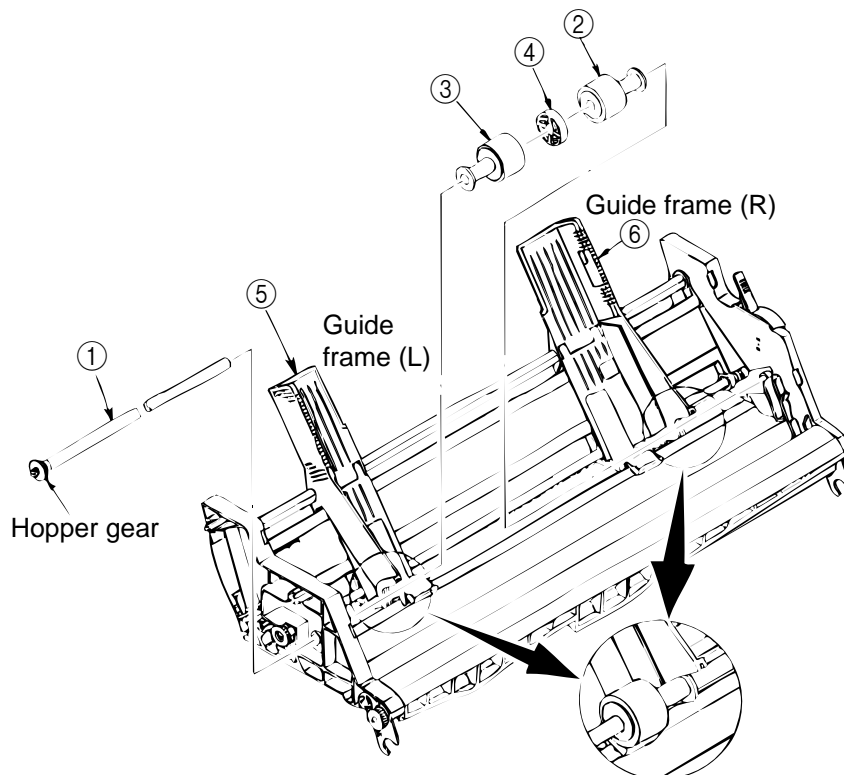

3.2.5 Brake Shoe

Be sure to replace both brake shoes at the same time. If you replace either one separately, this may cause paper skewing later.

1. Remove the side cover (L). (See 3.2.1.)
2. Remove the pulse motor (hopping). (See 3.2.3.)
3. Remove the hopping roller assembly. (See 3.2.4.)
4. Remove the brake shoe springs ① and remove brake shoes ② from the guide frames (L) and (R).

Note: Be sure not to lose the brake shoe springs ①.

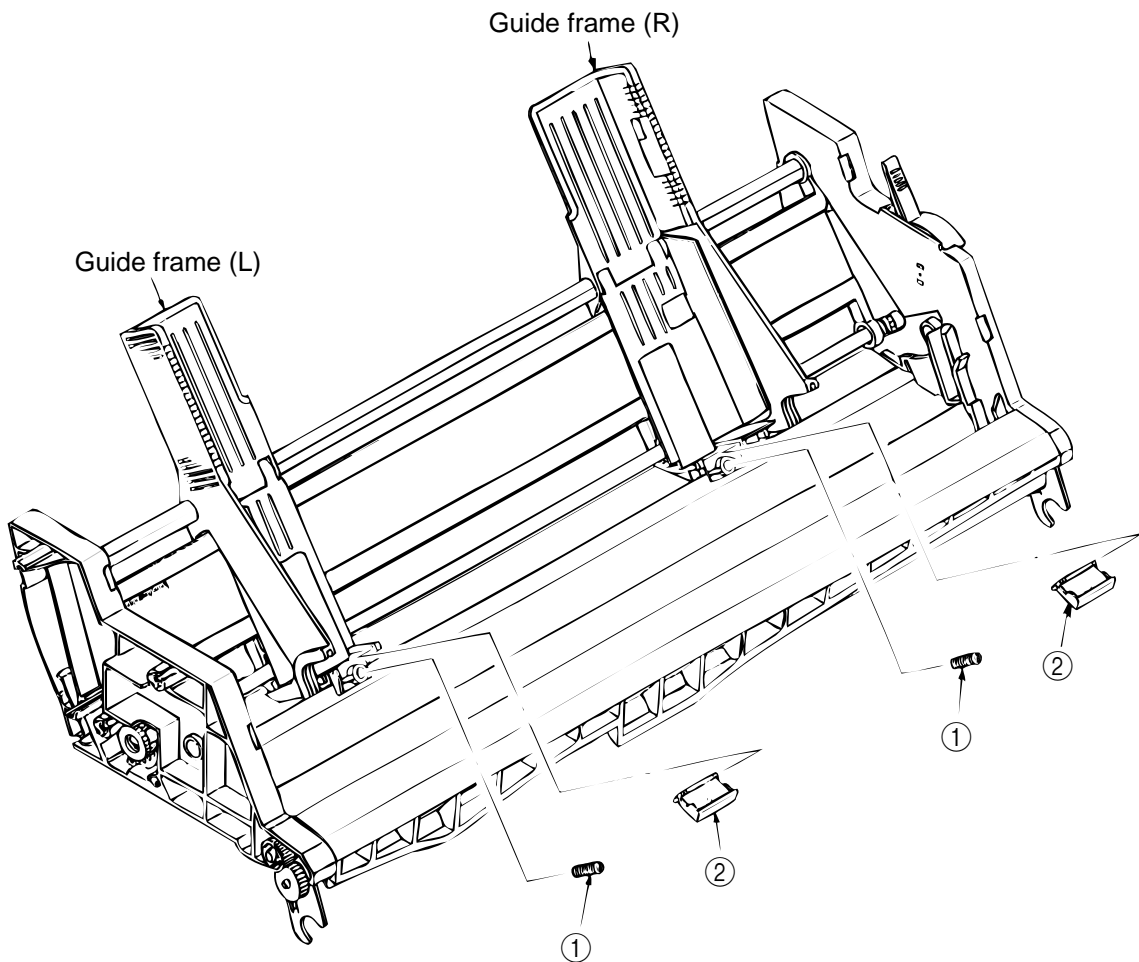

3.2.6 Friction Sheet

Be sure to replace both friction sheets at the same time. If you replace either one separately, this may cause paper skewing later.

1. Remove the hopping Roller Assy. (See 3.2.4.)
2. Move the paper set lever back and peel off friction sheets ② from the paper guides (R) and (L).

Note on installation:

- Peel off the release papers on the rear side of the friction sheets and stick the sheets on the paper guides (R) and (L).

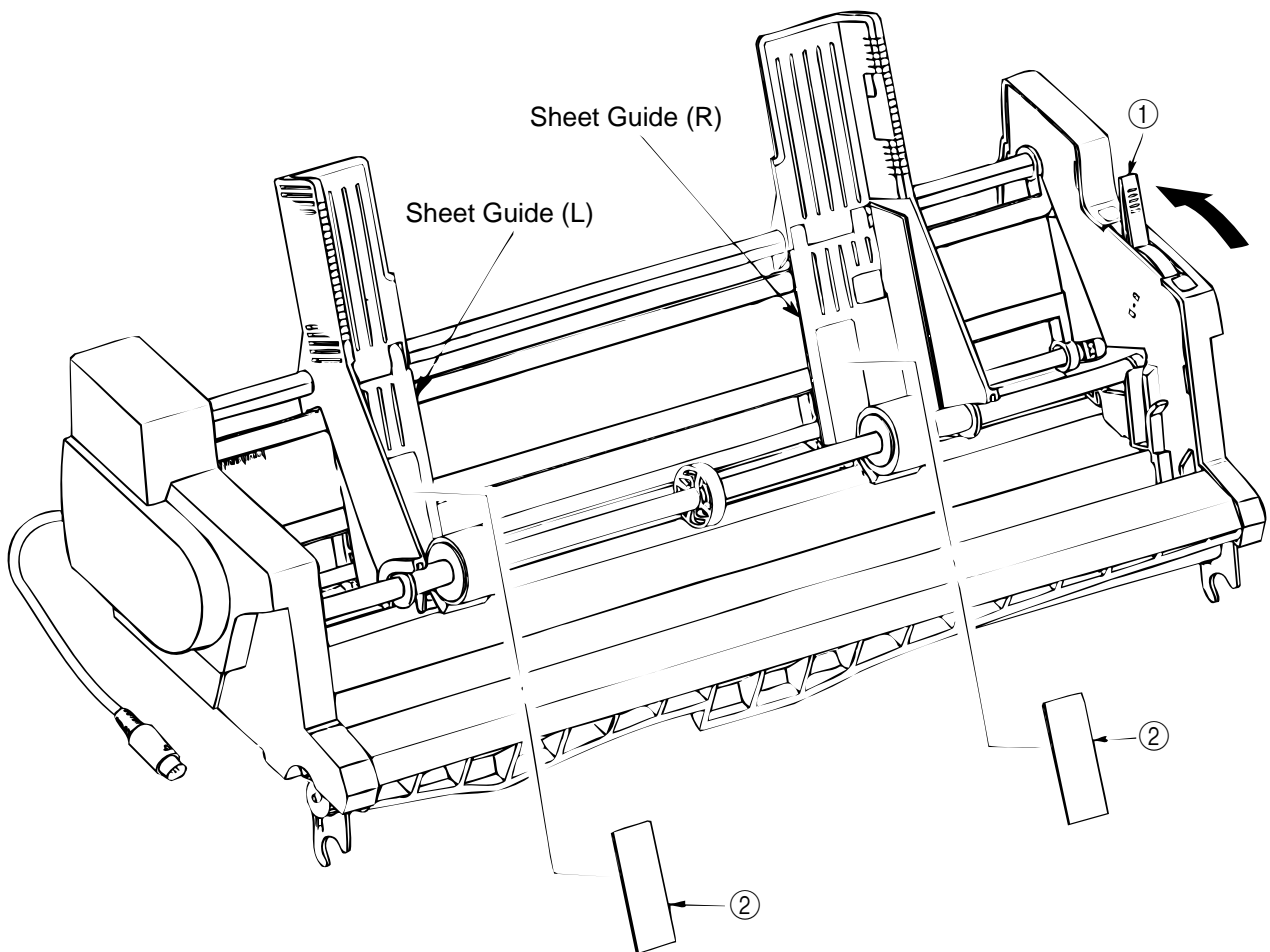

3.2.7 Side Cover (L), (R)

Use the following procedure to remove the side cover (L) and (R).

1. Insert a straight flat blade edge screwdriver into the five locking devices on each of the side covers (L) ① and (R) ② and unlock them.
2. Detach side covers (L) ① and (R) ② from the side brackets (L) ③ and (R) ④ respectively.

Note on disassembly:

- Make sure all locking devices are completely unlocked before removing side covers.

Note on reassembly:

- Be sure to insert the side covers straight along the side brackets until they lock.
- Side cover (R) installation
When installing the side cover (R), make sure that the Paper Set Lever is on the set side.
- Side cover (L) installation
When installing the side cover (L), be careful not to pinch the connector cable.

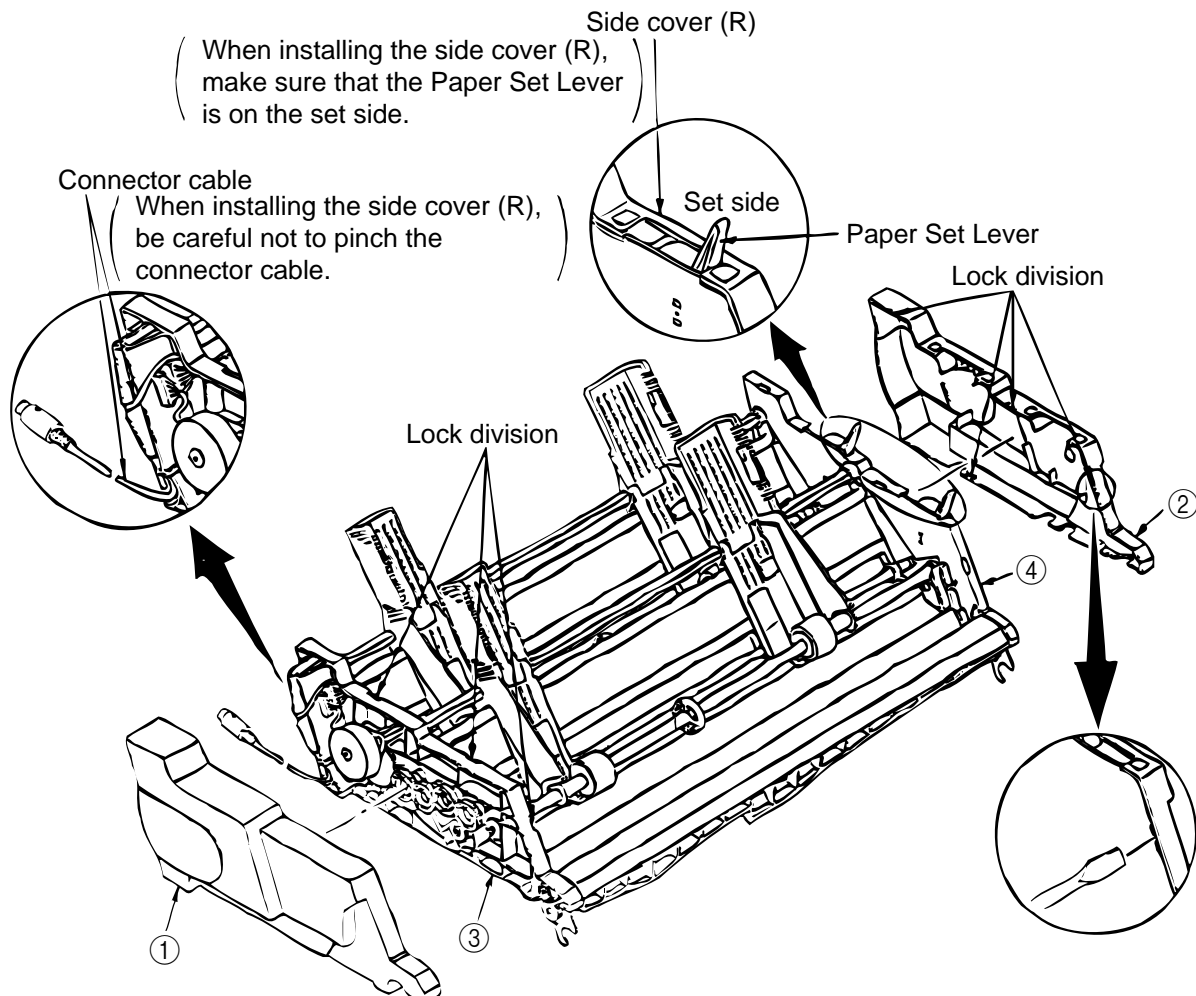

3.2.8 Circuit Board NCSF-2

1. Remove the side cover (L). (See 3.2.7.)
2. Pull out the circuit board NCSF-2 ①.
3. Disconnect the cable ② connected with the circuit board NCSF-2 ①.

Note on reassembly:

- Insert the circuit board NCSF-2 along the grooves of both upper and lower guides. Make sure it is flush inside the side bracket.

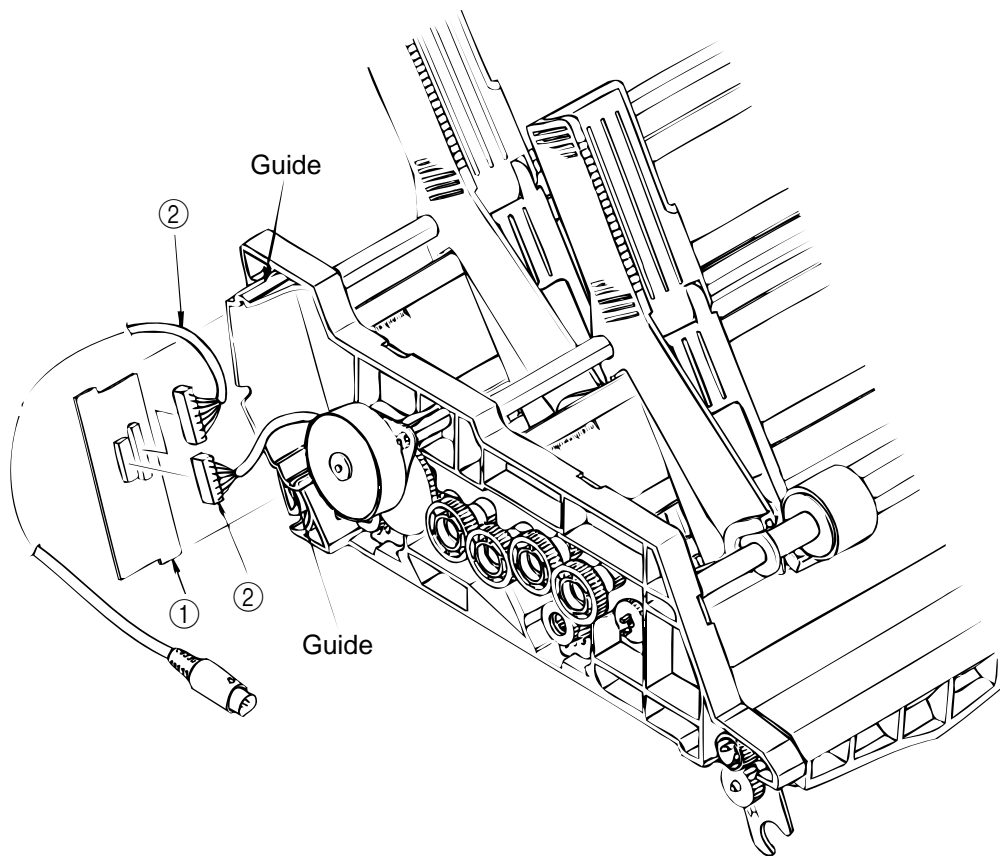

3.2.9 Pulse Motor (Hopping)

1. Remove the side cover (L). (See 3.2.7.)
2. Remove the circuit board NCSF-2. (See 3.2.8.)
3. Squeeze top of two clamps, in the direction of arrows shown below, to remove the pulse motor (hopping) ①.
4. Remove the idle gear ② from pulse motor (hopping) ①.

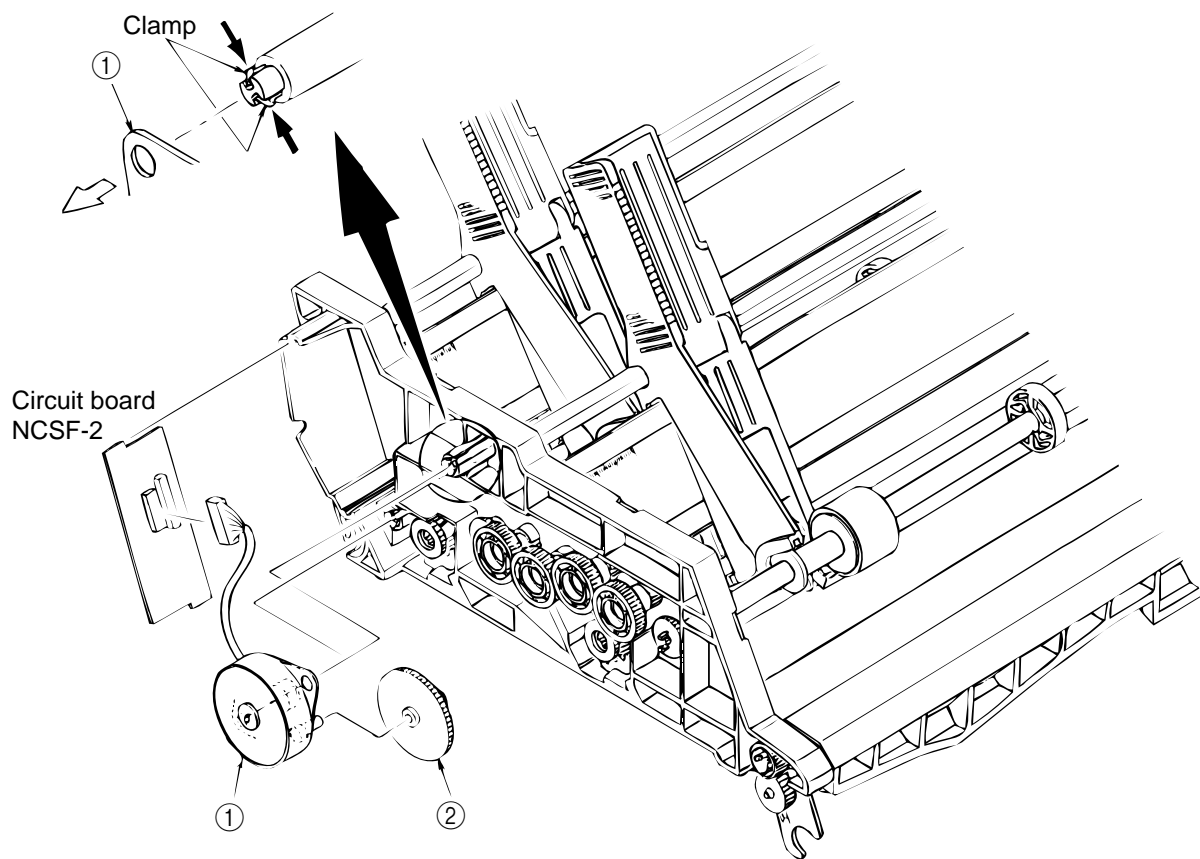

3.2.10 Sheet Guide

1. Remove the side cover (L) and (R). (see 3.2.7.)
2. Remove the four screws ① and take out the sheet guide ②.

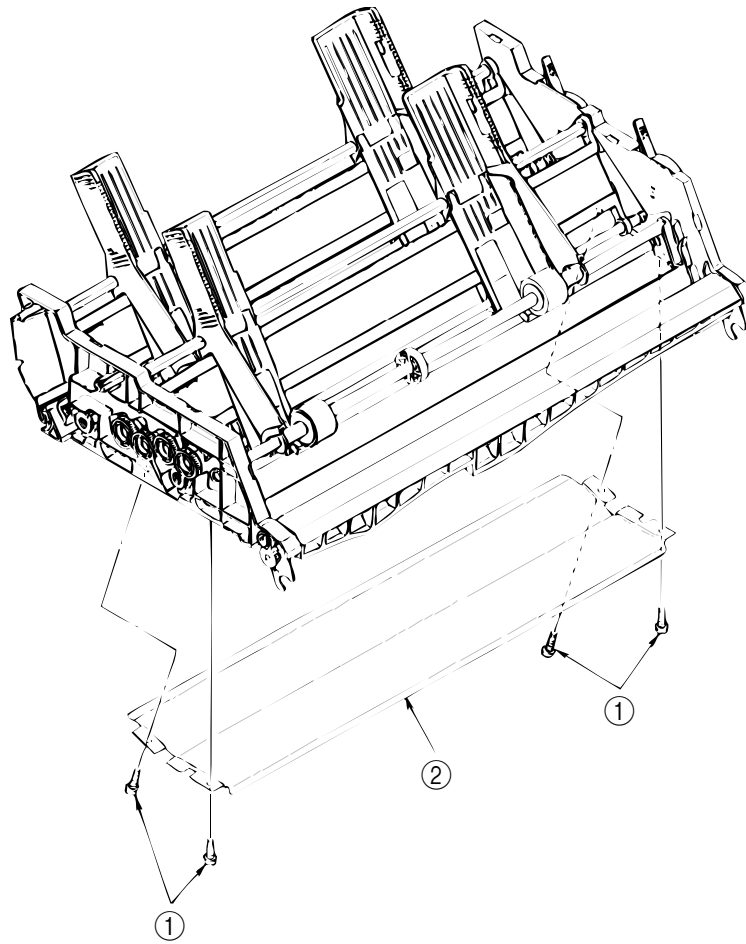

3.2.11 Hopping Roller Assy

- There are two hopping roller assemblies (left and right) and their bearing colors are different.

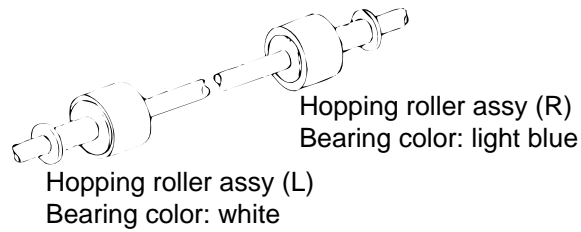

- Be sure to replace both hopping roller assemblies at the same time. If you replace either one separately, this may cause paper skewing later.
1. Remove the side cover (L). (See 3.2.7.)
 2. Remove the pulse motor (hopping). (See 3.2.9.)
 3. Pull out the hopper shafts ① together with the hopper gear.
At this point, the hopper roller assemblies (R) ② and (L) ③ and the guide roller ④ are removed from the shaft.

Note: Be sure not to lose the brake shoe springs.

Notes on reassembly:

- Be sure not to exchange the hopping rollers (R) and (L) when you reinstall them.
- Be sure to insert the flanges of the hopper rollers (R) and (L) into the grooves of the paper guides (R) ⑥ and (L) ⑤ and then reinstall hopper shafts ①.

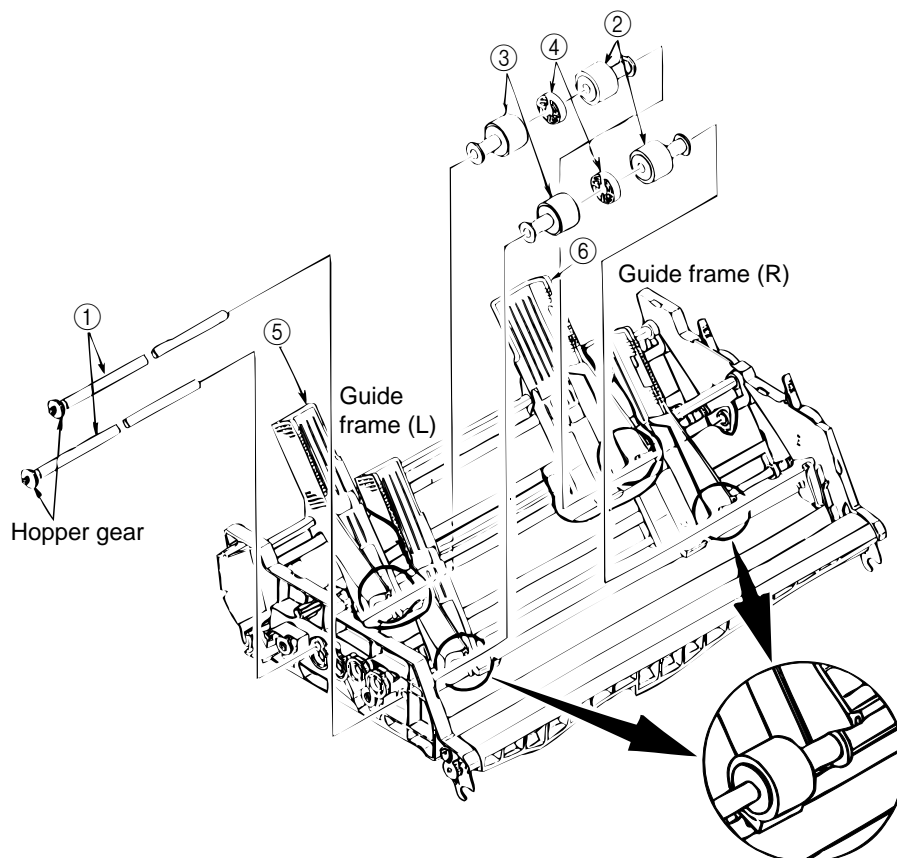

3.2.12 Brake Shoe

Be sure to replace both brake shoes at the same time. If you replace either one separately, this may cause paper skewing later.

1. Remove the side cover (L). (See 3.2.7.)
2. Remove the pulse motor (hopping). (See 3.2.9.)
3. Remove the sheet guide. (See 3.2.10.)
4. Remove the hopping roller assembly. (See 3.2.4.)
5. Remove the brake shoe spring ① and remove brake shoes ② from the guide frames (L) and (R).

Note:

- Be sure not to lose the brake shoe springs ①.
- It is easier to treat from bottom to place when replacing the brake shoes of the Rear Bin.

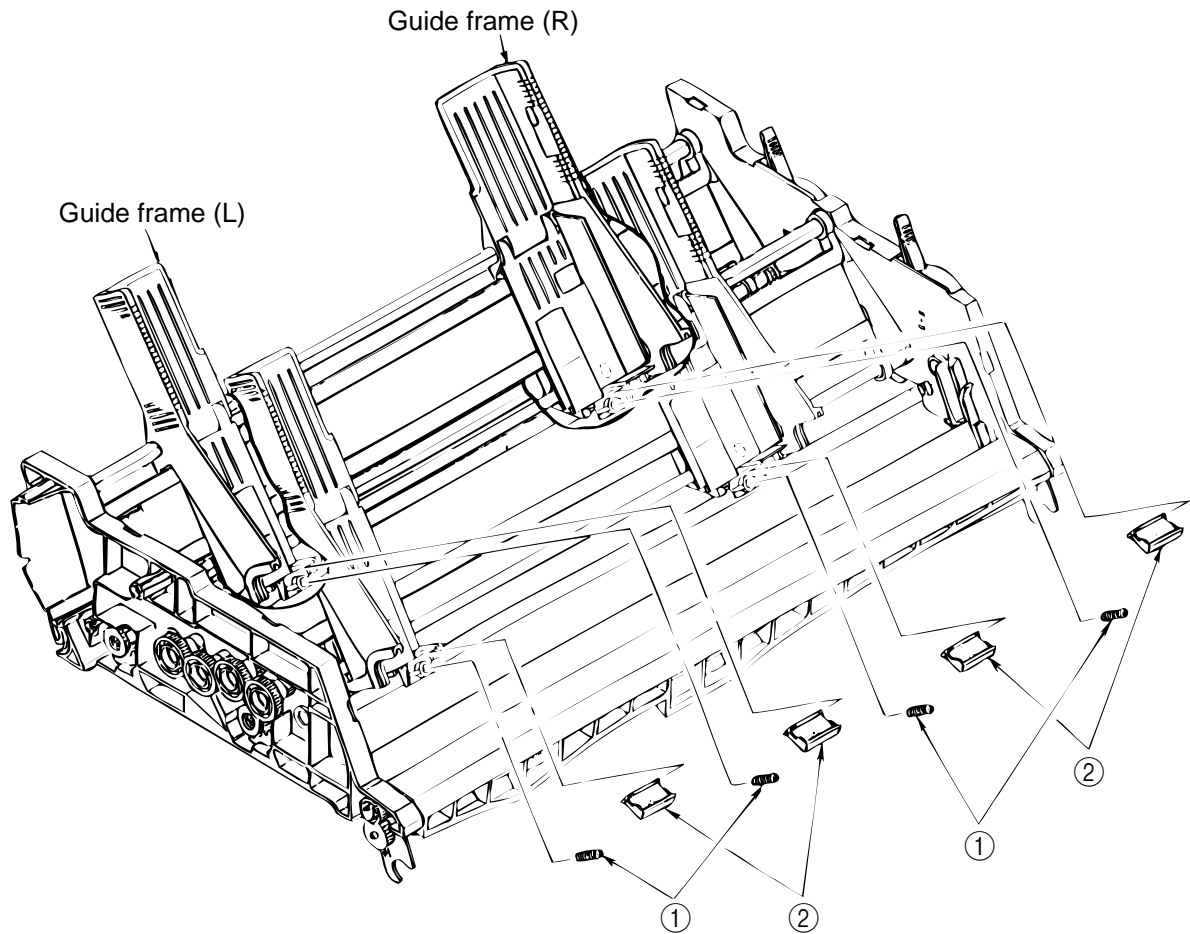

3.2.13 Friction Sheet

Be sure to replace both friction sheets at the same time. If you replace either one separately, this may cause paper skewing later.

1. Remove the hopping Roller Assy. (See 3.2.11.)
2. Move the paper set lever ① back up and peel off friction sheets ② from the sheet guides (R) and (L).

Note on installation:

- Peel off the release papers on the rear side of the friction sheets and stick the sheets on the paper guides (R) and (L).

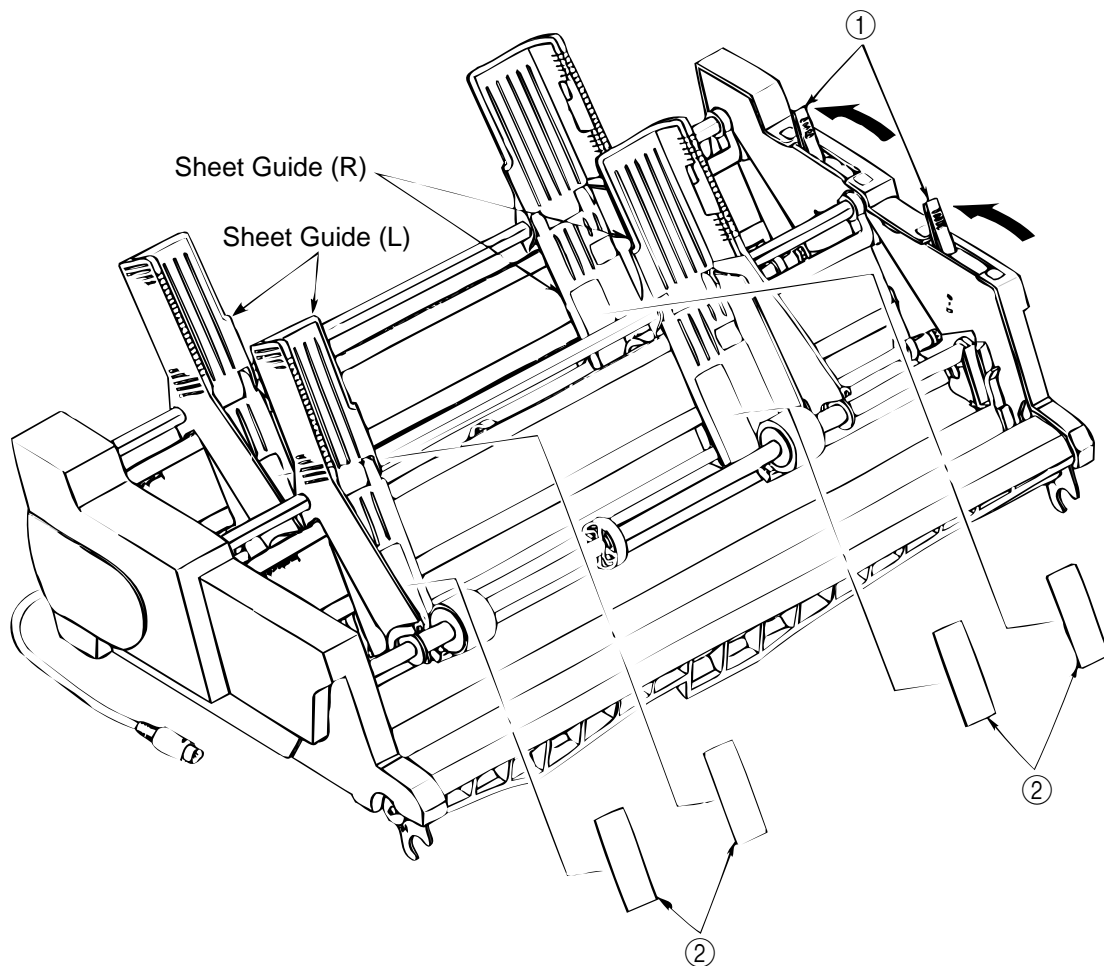

3.2.14 Attachment Assy

1. Detach paper end assembly ① from sheet guide ②.
2. Remove tape cover ③ from sheet guide ②.

Note : Be careful not to lose coil spring.

– When reassembling, fit the coil spring between post and rib, then attach the paper end assembly ① with the coil spring in contact with the back face of sheet guide ②.

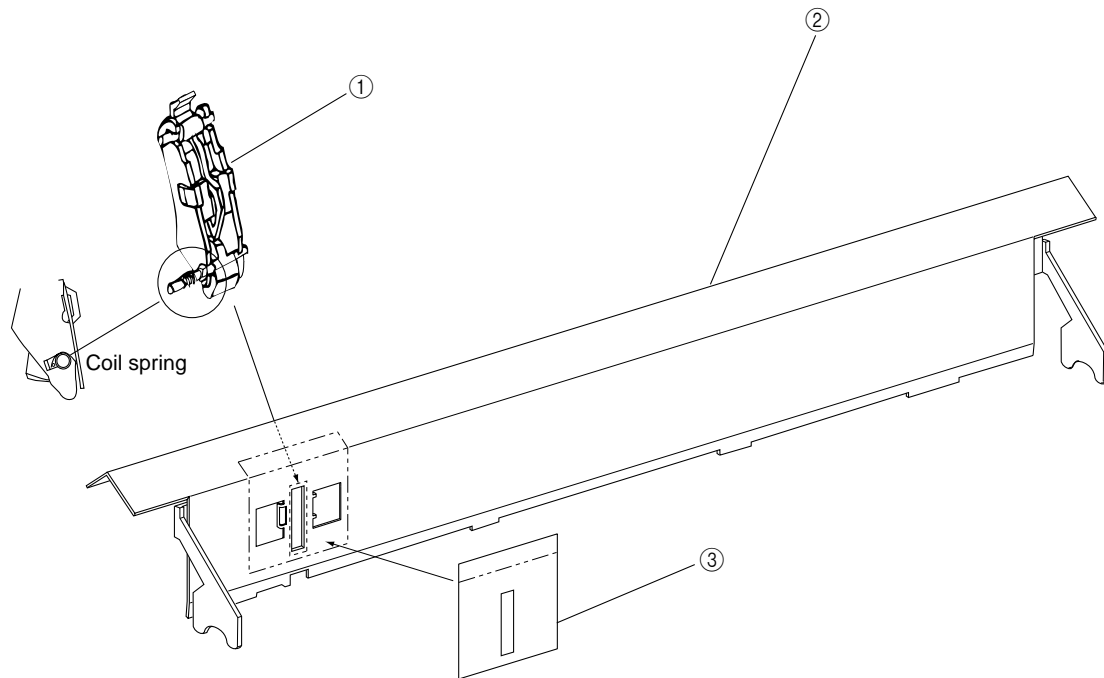

4. PERIODIC MAINTENANCE

4. PERIODIC MAINTENANCE

4.1 Periodic Replacing Parts

As specified below, the part shall be replaced periodically.

No.	Part name	Part number	Replacement cycle
1	Hopping roller Assy (L)	4PB4053-1705G1	Either: (a) 3 years of operation or (b) 100,000 sheets of paper feed, whichever takes place first.
2	Hopping roller Assy (R)	4PB4053-1705G2	The same as the above
3	Brake shoes	4PP4053-2547G1	The same as the above

4.2 Lubrication

(1) Preventive inspection timing

The CSF is a maintenance-free machine which requires no lubrication while it operates. Lubrication is required, however, when you disassemble and reassemble the unit, clean the lubricated parts, and replace a part.

- Alvania grease #2EP(Showa Shell Oil Co., Ltd. equivalent) GEP
- Pan motor oil 10W-30(Nippon Oil Co., Ltd. equivalent) PM

(2) Lubrication amount

- Large amount: Ⓐ Lubricate fully.
- Standard amount: Ⓑ Apply 3 to 4 drops. In case of grease, apply in a layer approximately 0.2mm thick.
- Small amount: Ⓒ Apply about 1 drop.

(3) Locations where lubrication is prohibited

Location where lubrication is prohibited	Reason	Remarks
Hopper	To prevent smudges on paper.	
Sheet guide	To prevent smudges on paper.	
Stacker	To prevent smudges on paper.	
Hopper roller	To prevent smudges on paper.	
Brake shoe	To prevent smudges on paper.	

Also, do not lubricate other parts that may cause smudges on paper.

(4) Locations to be lubricated

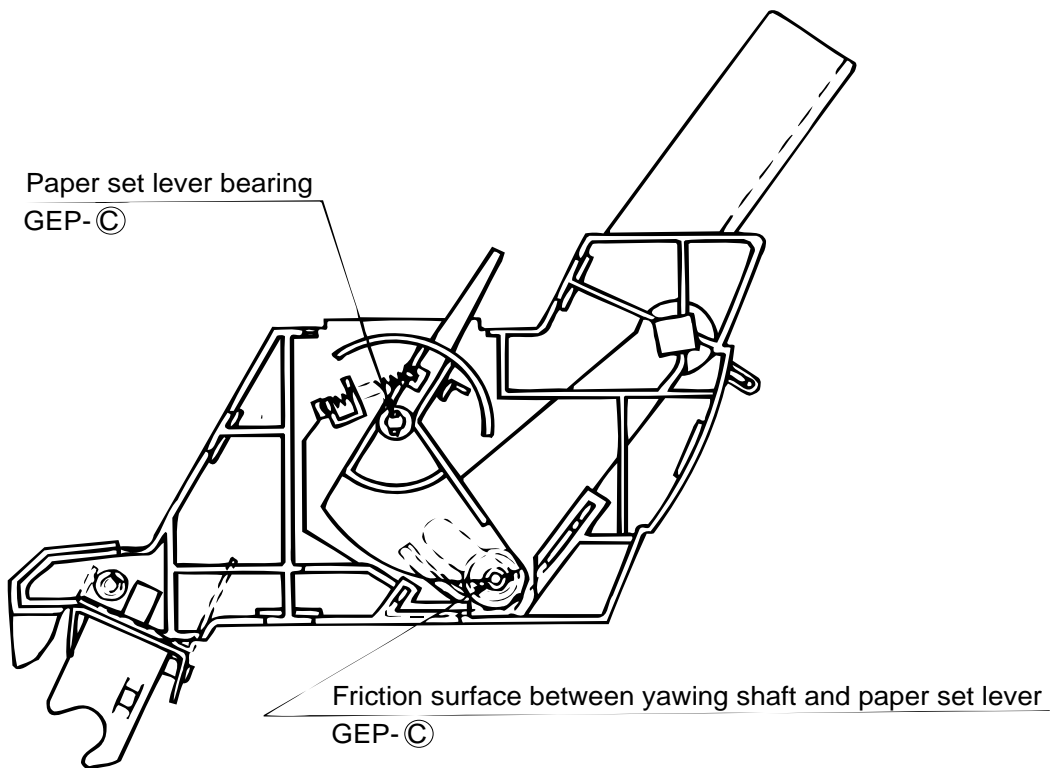
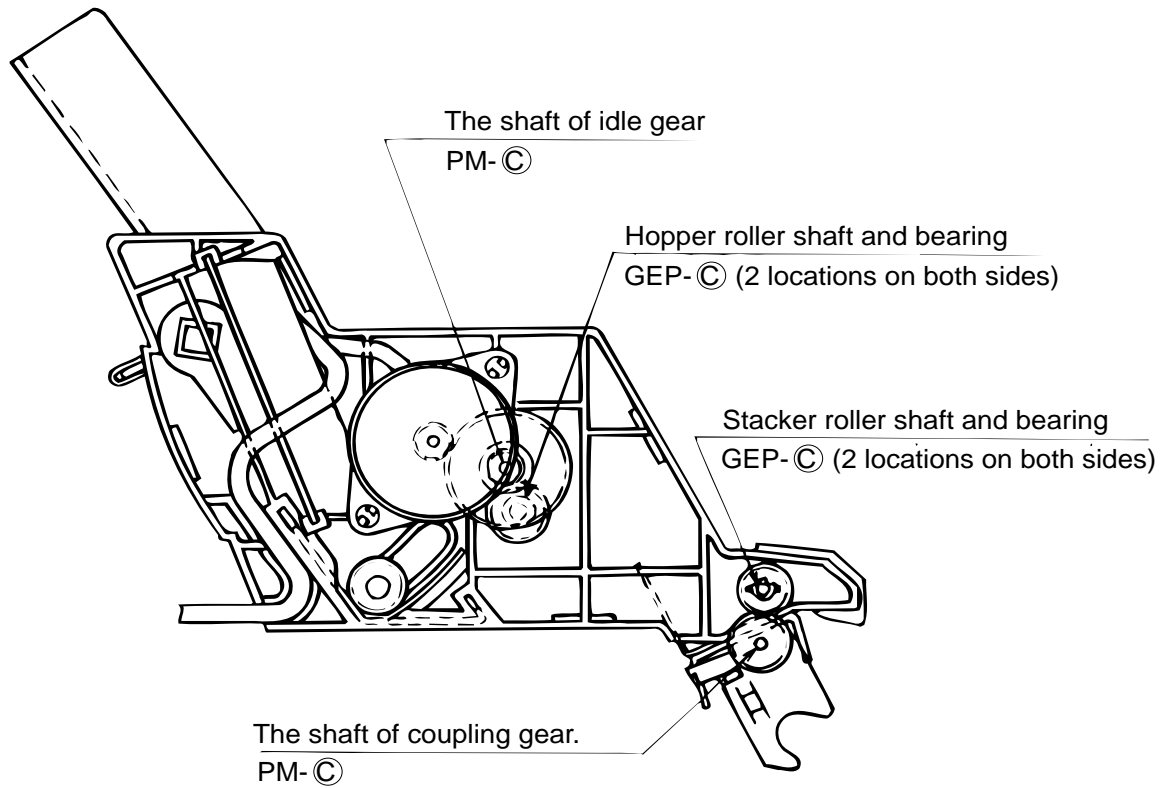

CSF 3390-S / 3391-S

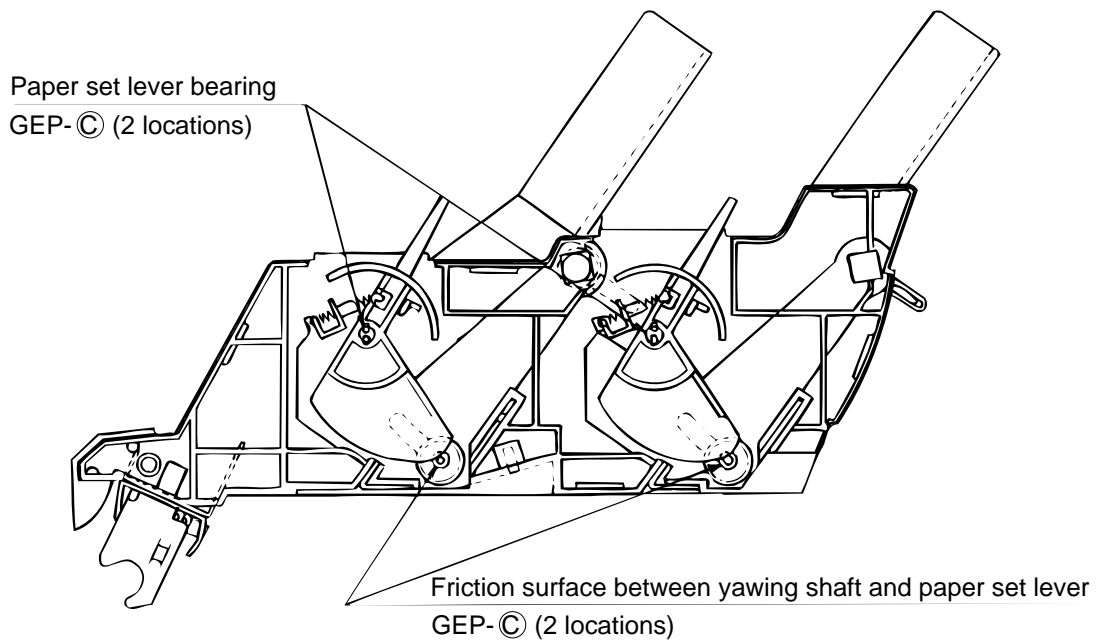
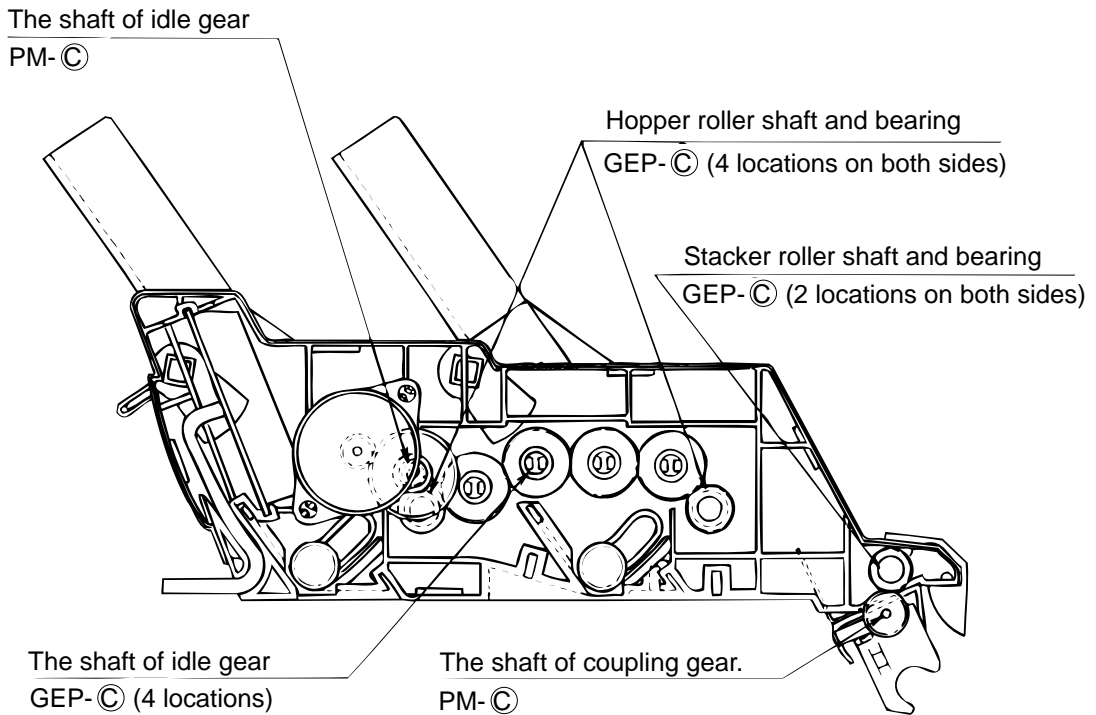

CSF 3390-D / 3391-D

5. TROUBLESHOOTING FLOWCHARTS

See the troubleshooting flowcharts below to locate a trouble and take required action. The flowcharts have been prepared for field service troubles. Refer to them only after you are thoroughly sure of the trouble symptoms and conditions.

①

No paper feed even when date is entered.

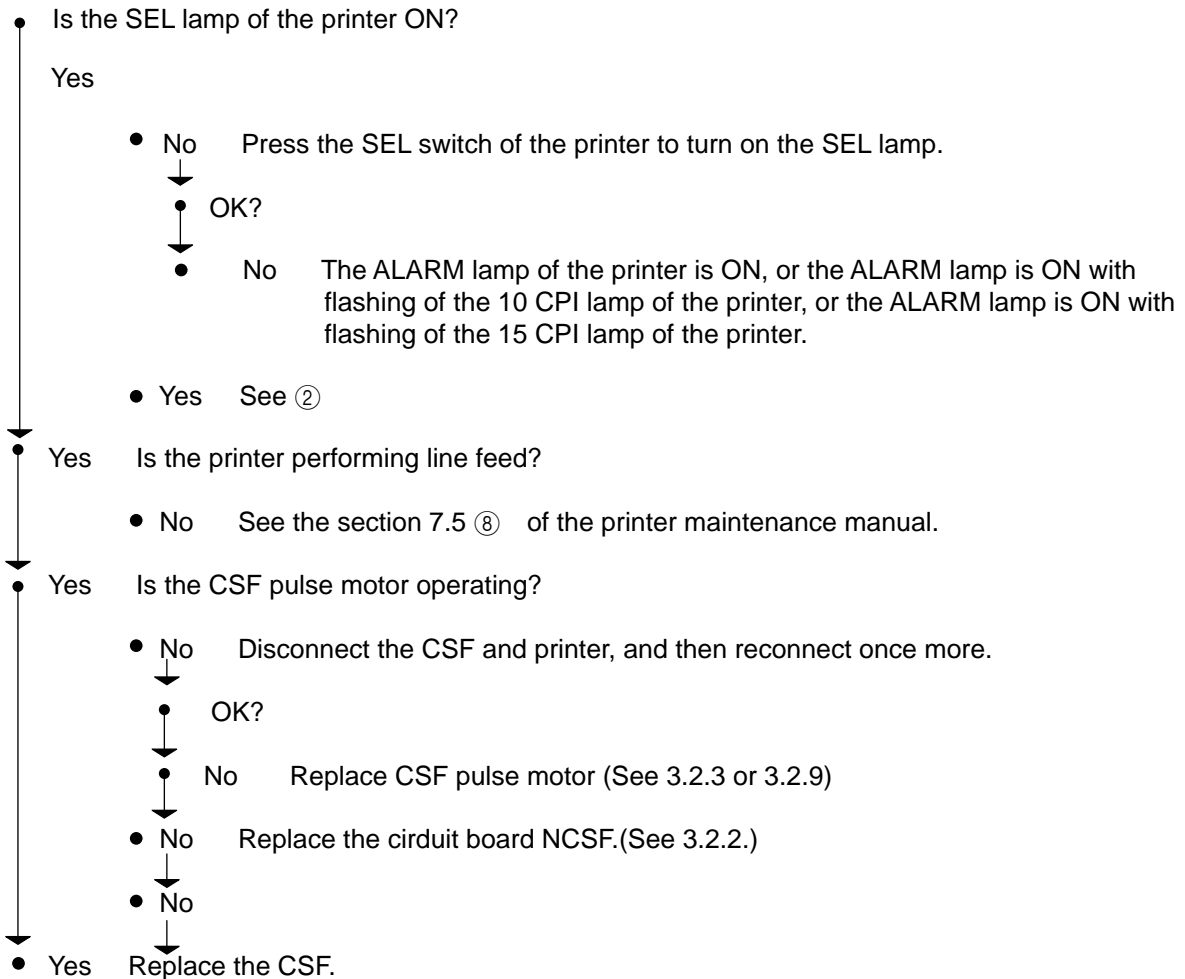

②

No paper feed even when date is entered.

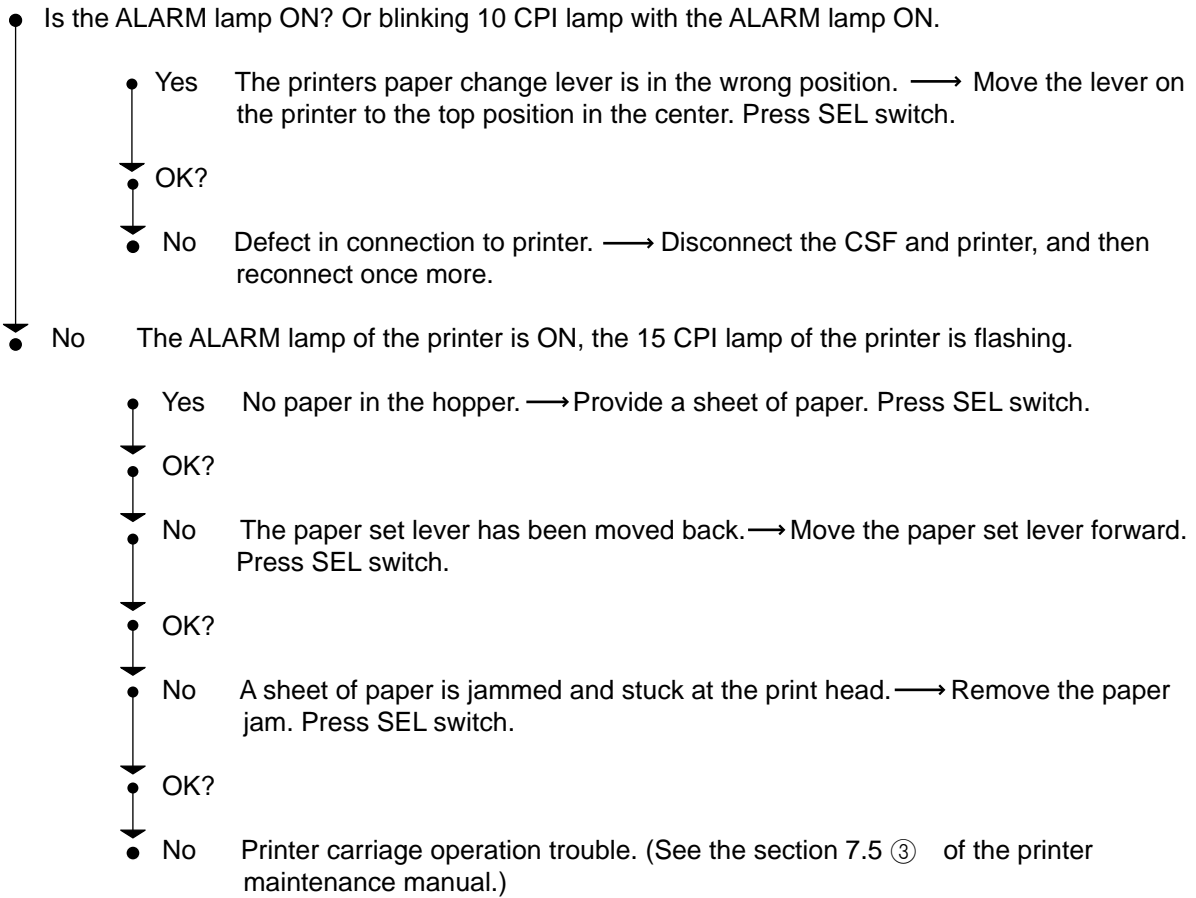

6. CIRCUIT DIAGRAM

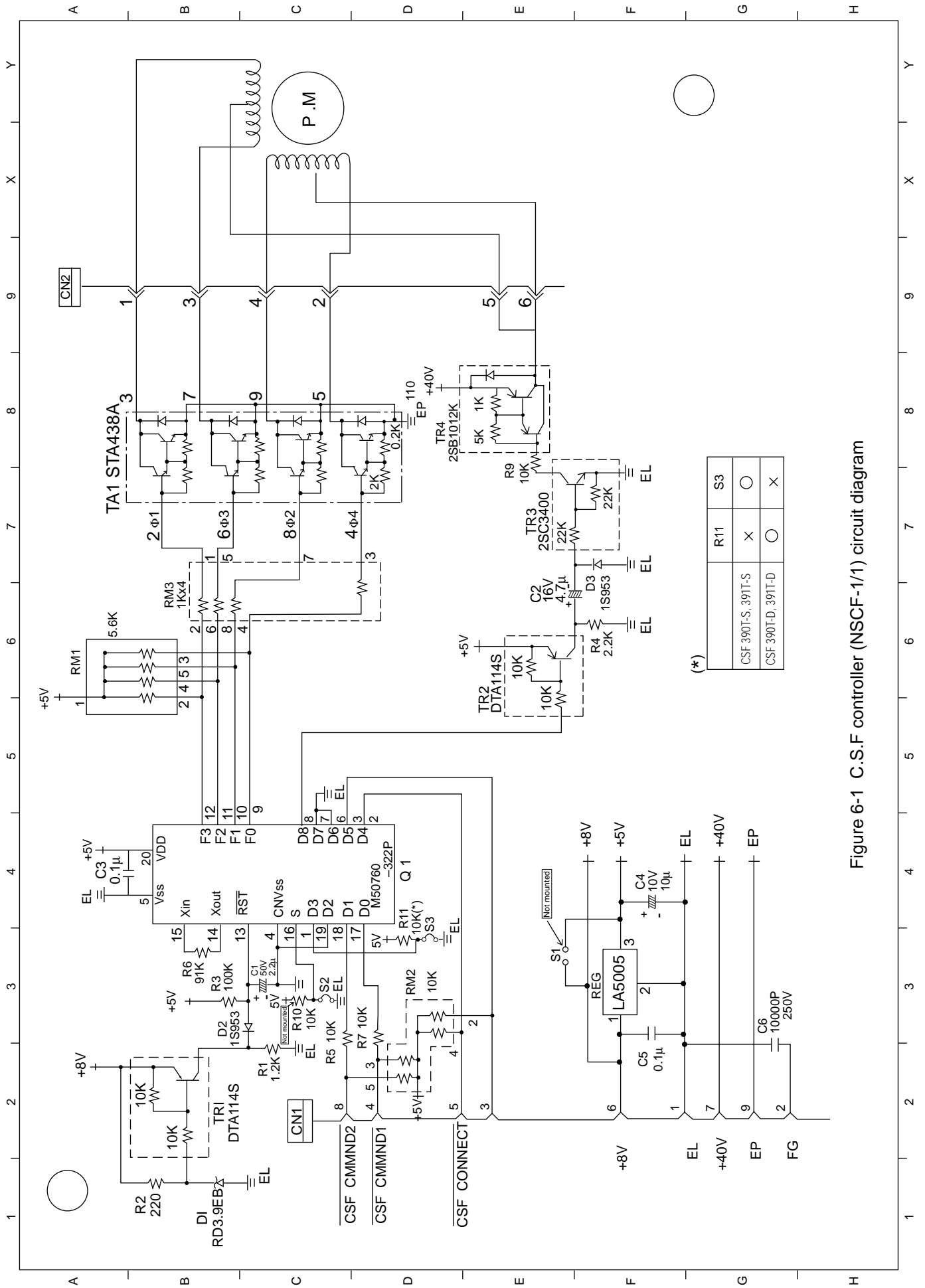

Figure 6-1 C.S.F controller (NSCF-1/1) circuit diagram

7. PARTS LIST

7-1

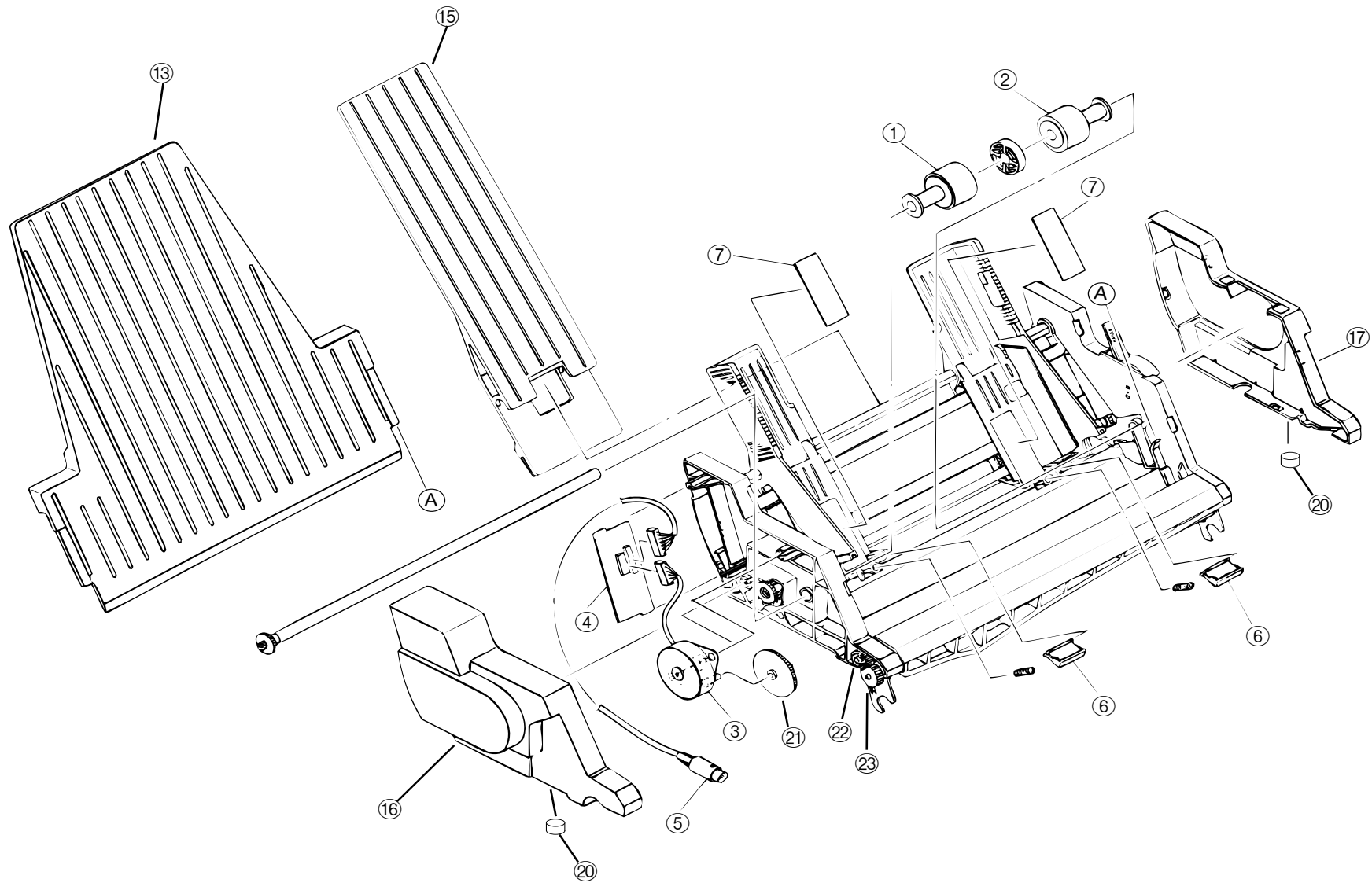

Figure 7-1 C.S.F 3390-S

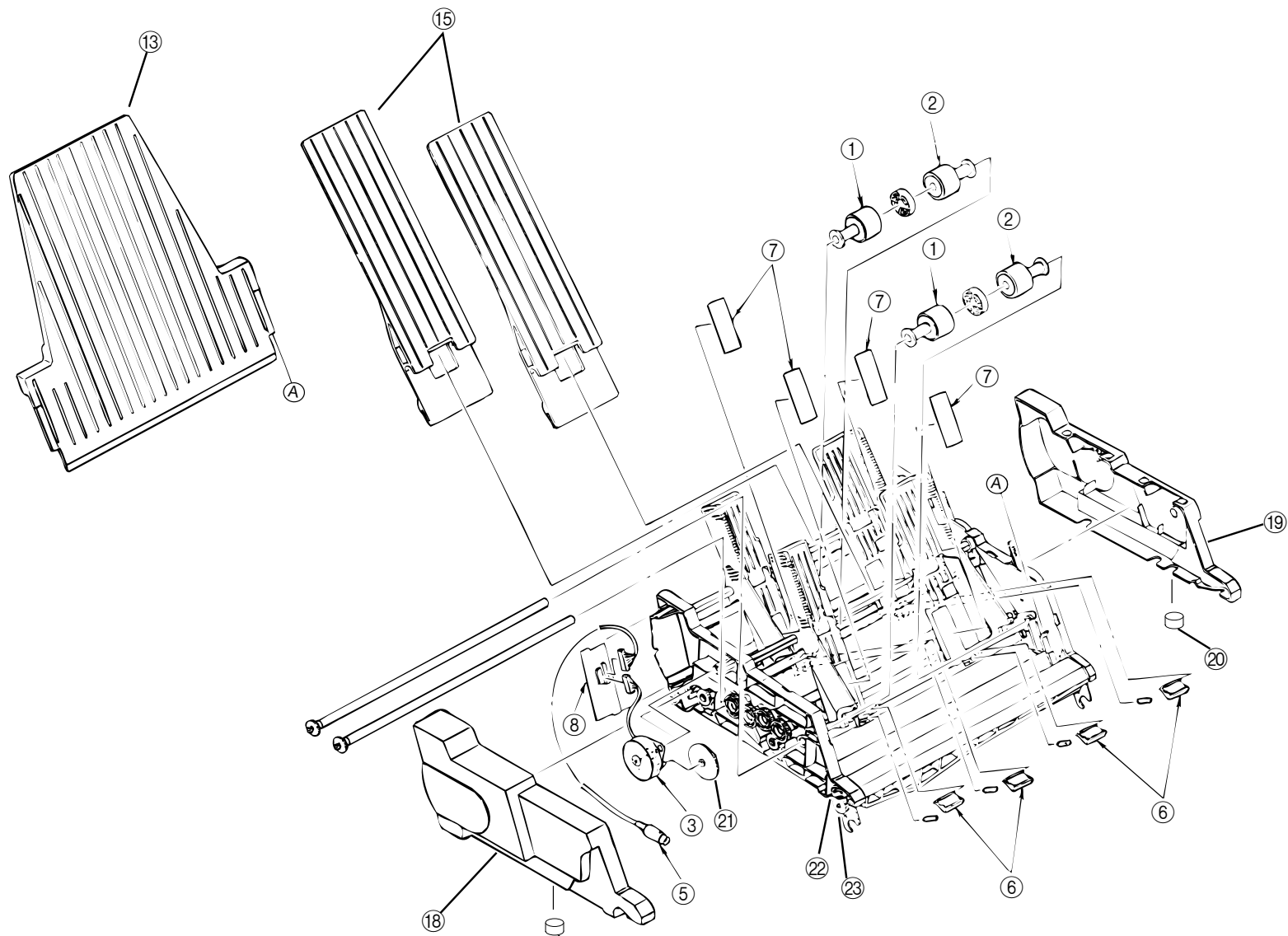

Figure 7-2 C.S.F 3390-D

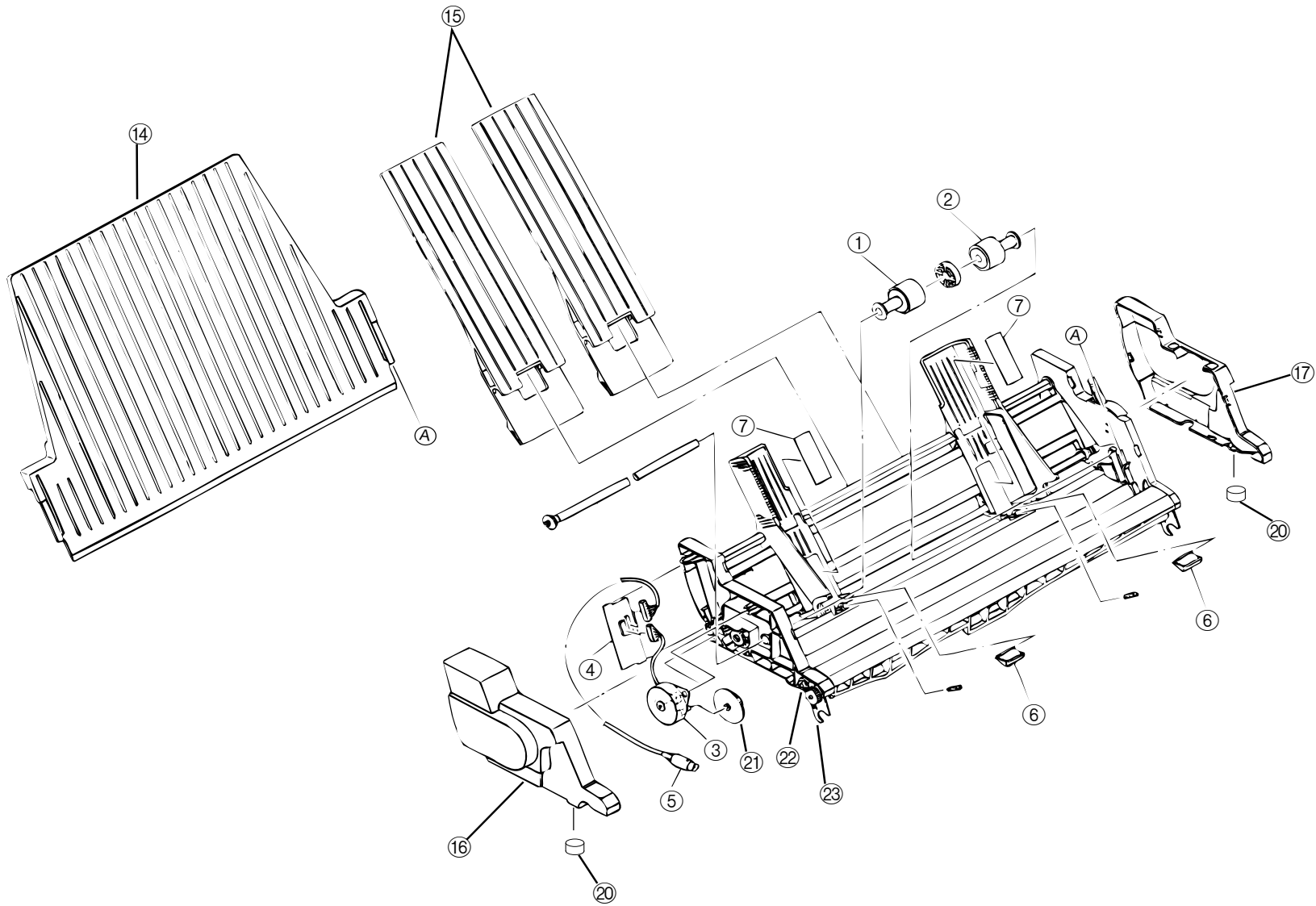

Figure 7-3 C.S.F 3391-S

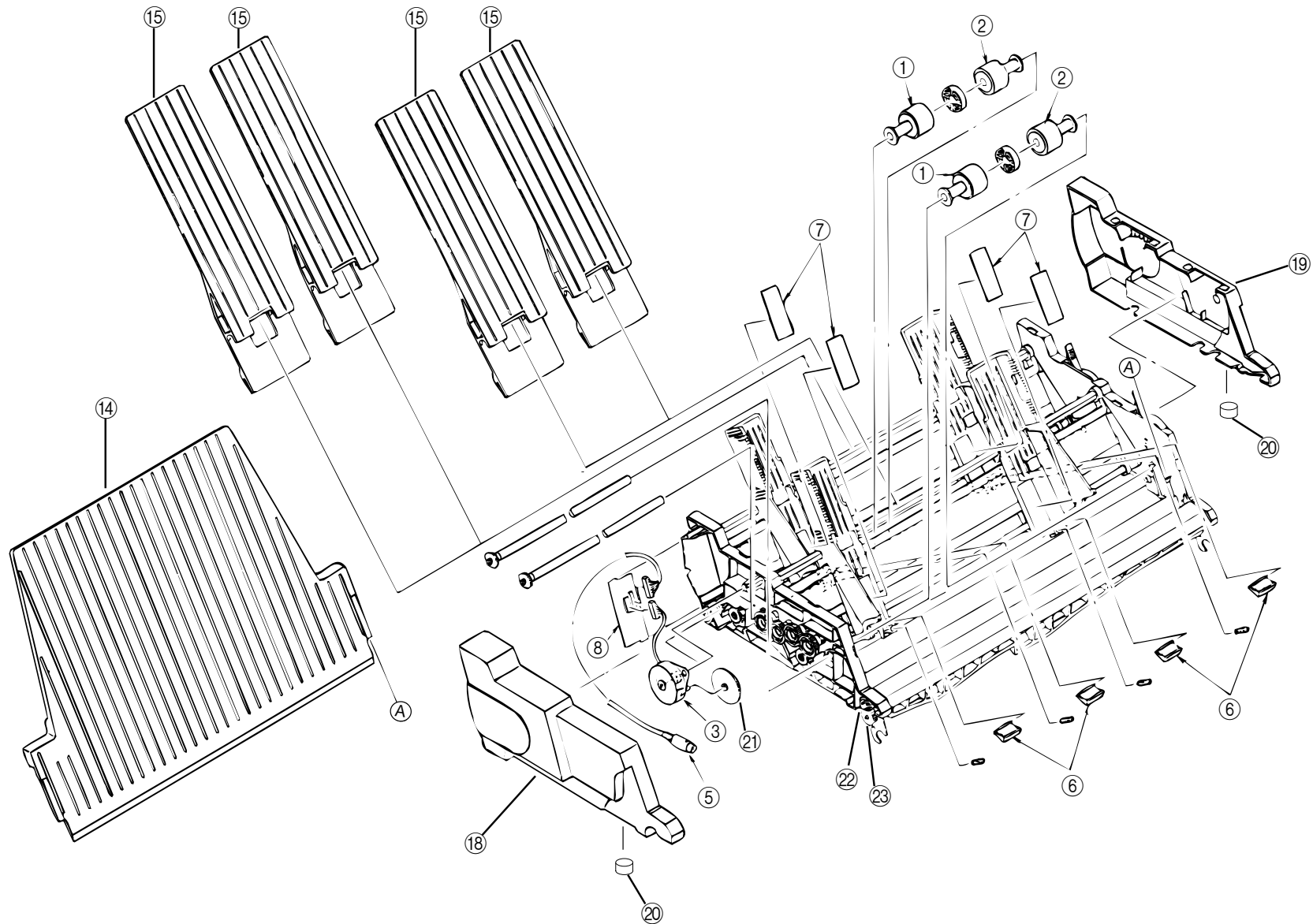

Figure 7-4 C.S.F 3391-D

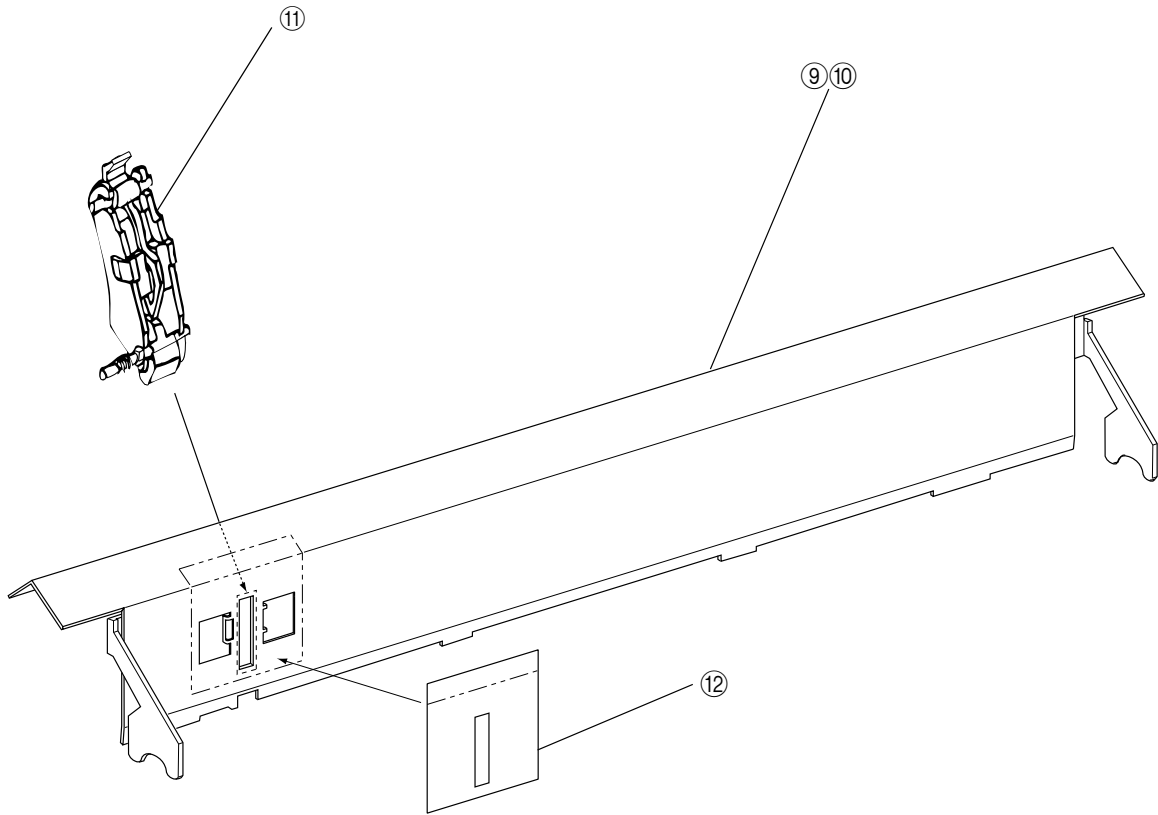

Figure 7-5 Attachment Assy

Table 7-1 Cut-Sheet Feeder Unit

No.	Name/Rating.	Parts No.	Q' ty				Remarks
			CSF 3390-S	CSF 3391-S	CSF 3390-D	CSF 3391-D	
1	Hopping roller Assy (L)	4PB4053-1705G1	1	1	2	2	
2	Hopping roller Assy (R)	4PB4053-1705G2	1	1	2	2	
3	Pulse motor (hopping)	3PB4053-2560P1	1	1	1	1	
4	Circuit board NCSF	4YA4050-3026G1	1	1	—	—	
5	Connector cord	3YS4011-5120G1	1	1	1	1	
6	Brake shoe	4PP4053-2547G1	2	2	4	4	
7	Friction sheet	4PB4025-1914P1	2	2	4	4	
8	Curcuit board NCSF-2	4YA4050-3026G2	—	—	1	1	
9	Sheet guide (N)	40270101	1	—	1	—	
10	Sheet guide (W)	40257601	—	1	—	1	
11	Paper end Assy	3PA4044-5252G1	1	1	1	1	
12	Tape cover	40259901	1	1	1	1	
13	Front sheet supporter (N)	1PP4053-2576P1	1	—	1	—	
14	Sheet supporter	1PP4043-1891P4	—	1	—	1	
15	Rear sheet supporter	3PB4025-1941P1	1	2	2	4	
16	Side cover (L)	1PP4053-2574P1	1	1	—	—	
17	Side cover (R)	1PP4053-2575P1	1	1	—	—	
18	Side cover (L)	1PP4053-2683P1	—	—	1	1	
19	Side cover (R)	1PP4053-2684P1	—	—	1	1	
20	Rubber foot	40043901	2	2	2	2	
21	Idle gear	4PB4025-1946P1	1	1	1	1	
22	Stacker gear	3PP4053-2569P1	1	1	1	1	
23	Coupling gear	4PP4025-3129P1	1	1	1	1	